

EGO™

POWER⁺ TOP HANDLE CHAINSAW

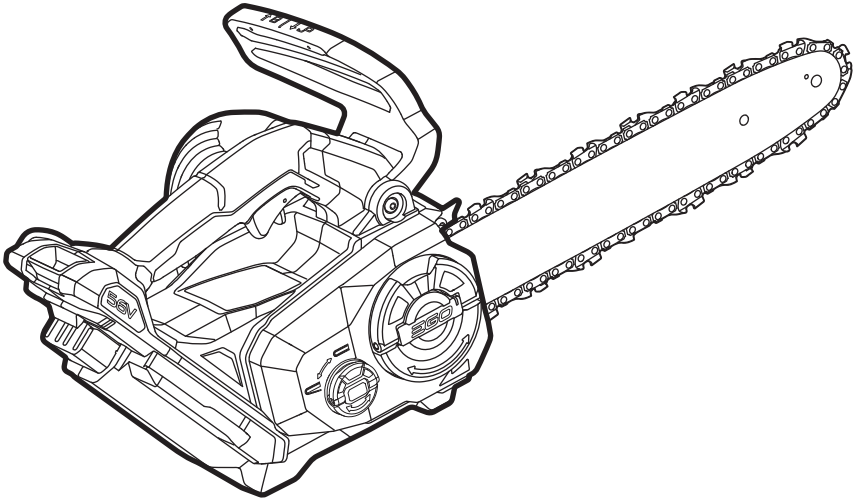

OPERATOR'S MANUAL

56 VOLT LITHIUM-ION CORDLESS TOP HANDLE CHAINSAW MODEL NUMBER CS1200E

† NOTE: CS1200E will only operate with
BA1400 & BA1400T (2.5Ah Battery).

⚠ WARNING: To reduce the risk of injury, the user must read and understand the Operator's Manual before using this product. Save these instructions for future reference.

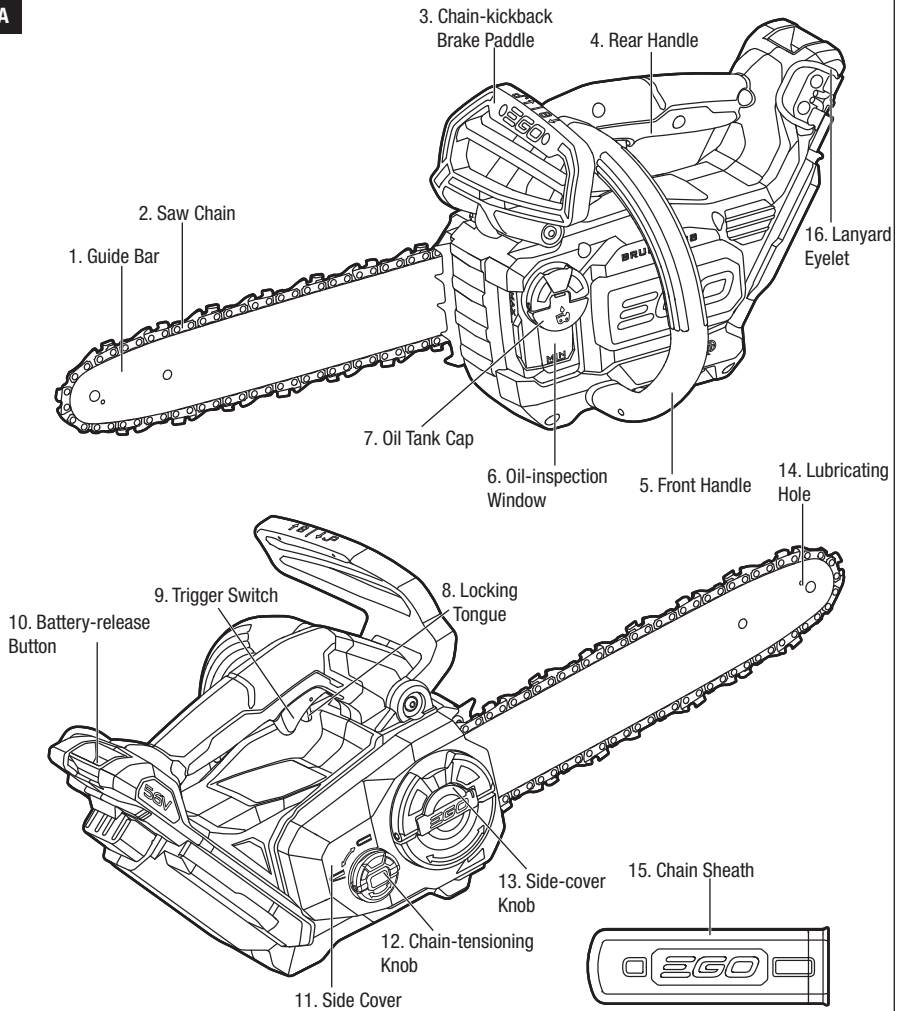
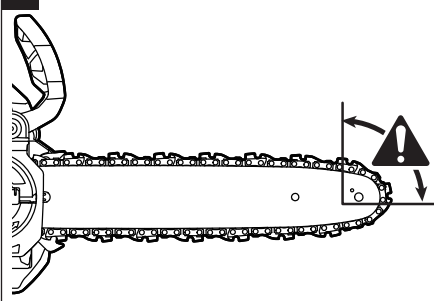
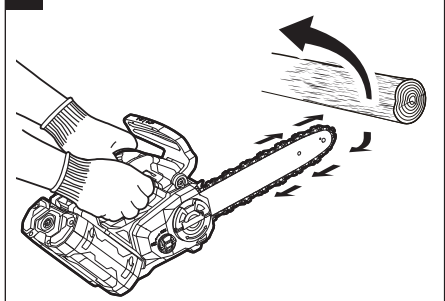
A**B****C**

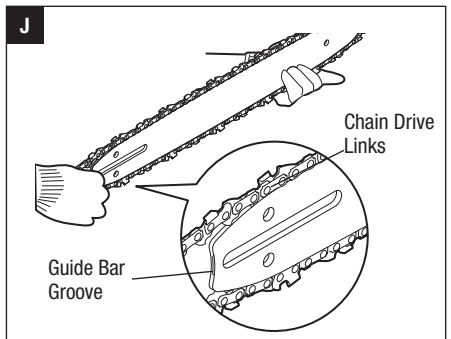
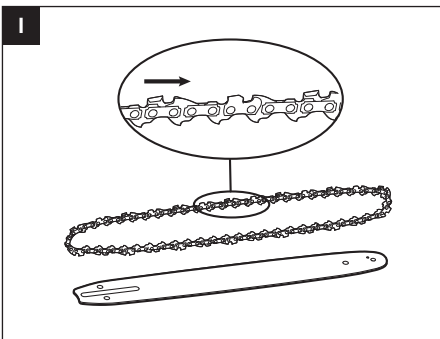
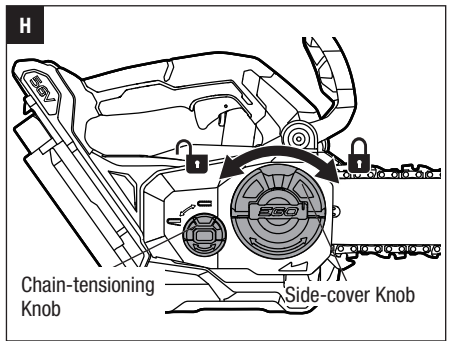
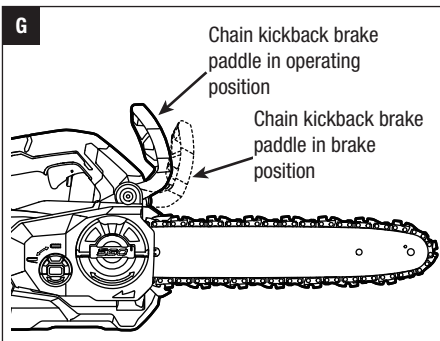
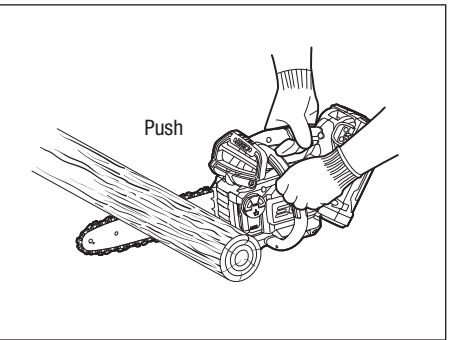
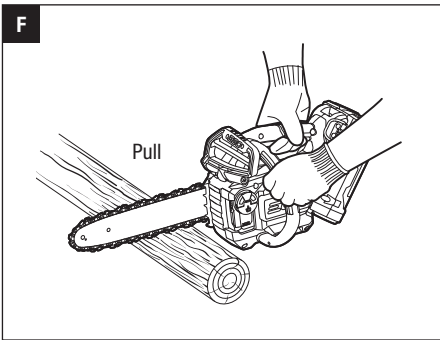
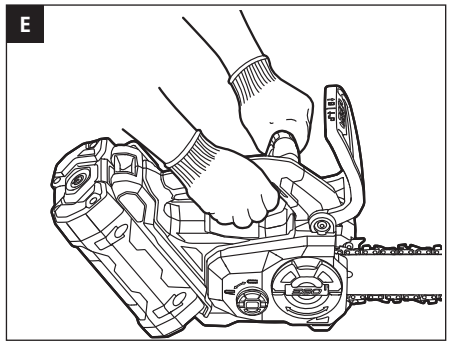
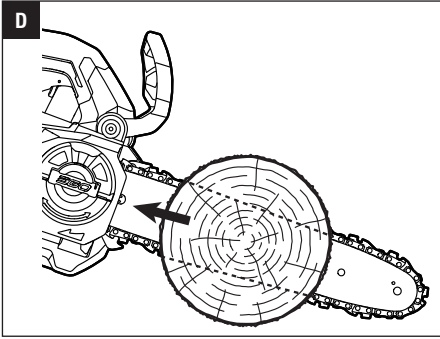

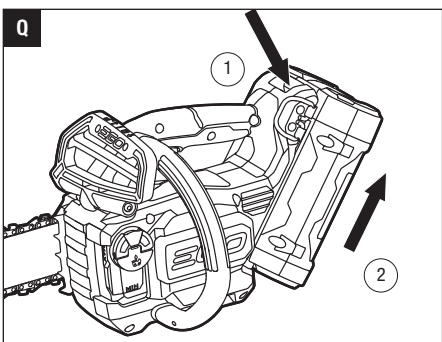
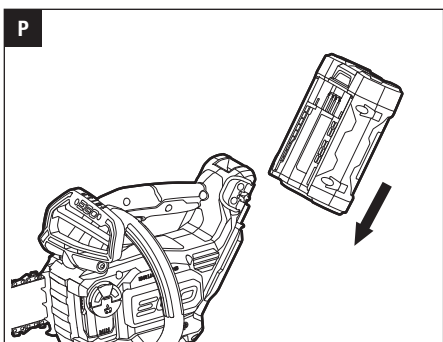
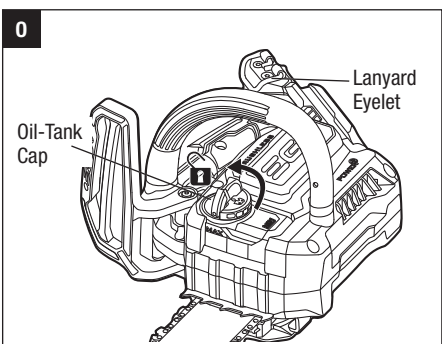
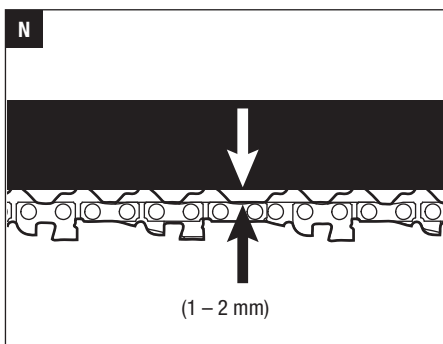
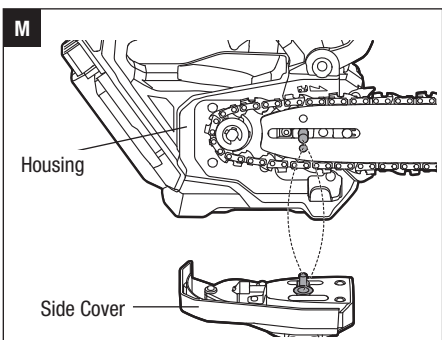
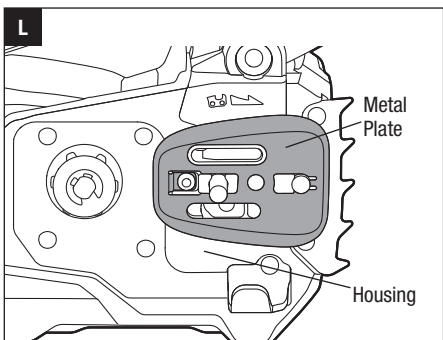
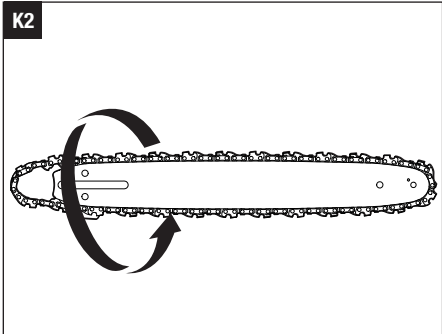
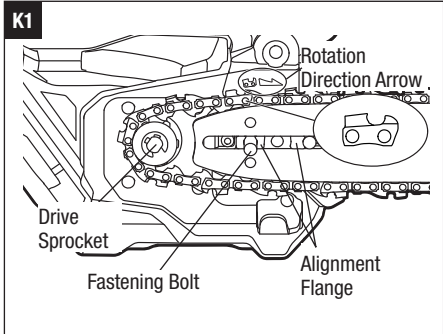

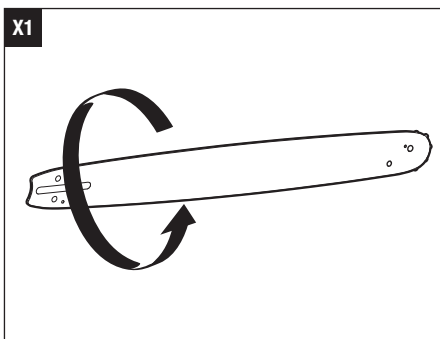
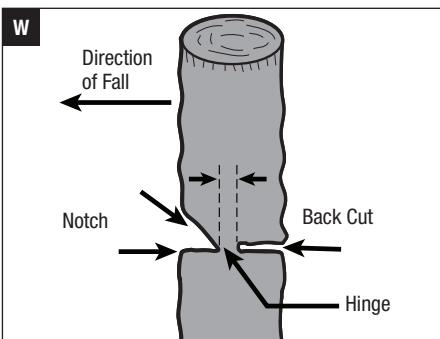
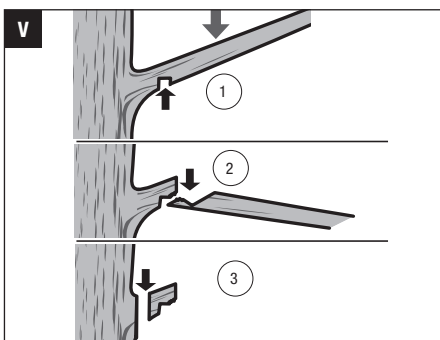
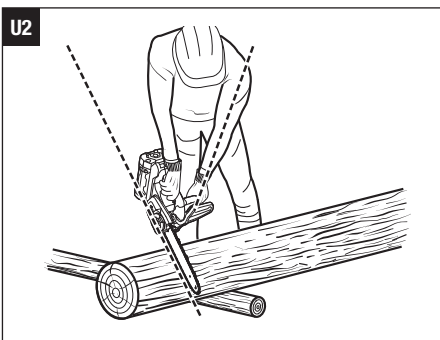
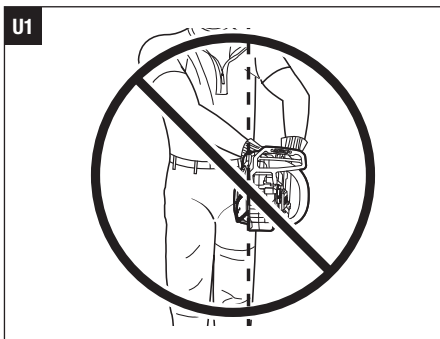
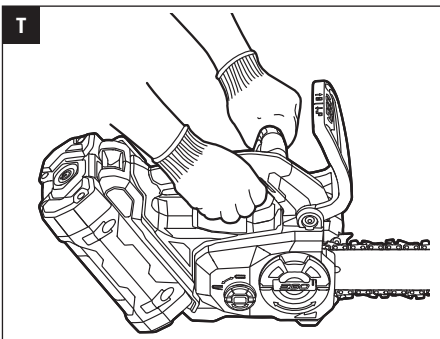
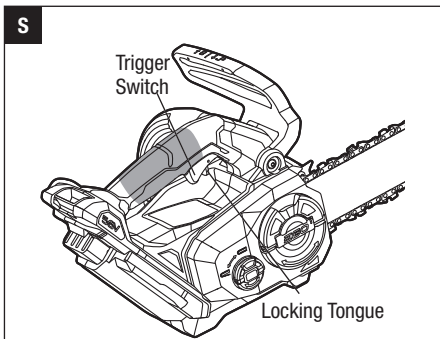
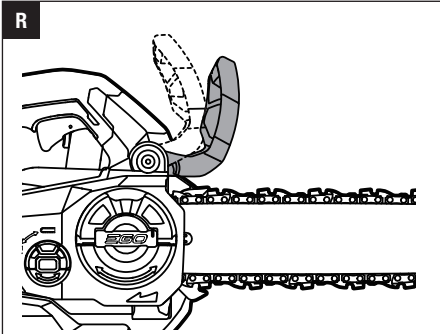

X2

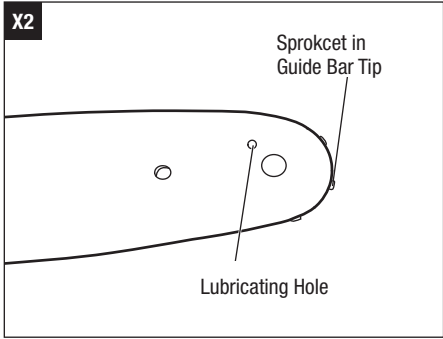

X3

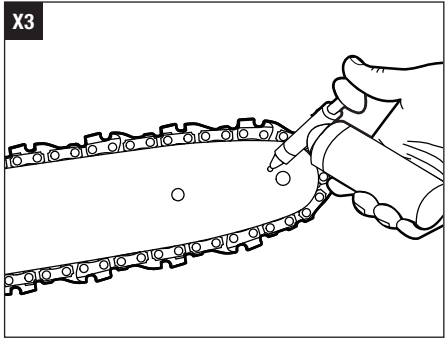

READ ALL INSTRUCTIONS!



READ OPERATOR'S MANUAL

NOTICE: These instructions shall also be available in an alternative format, e.g. on a website.

WARNING: To ensure safety and reliability, all repairs and replacements should be performed by a qualified service technician.

SAFETY SYMBOLS

The purpose of safety symbols is to attract your attention to possible dangers. The safety symbols and the explanations with them deserve your careful attention and understanding. The symbol warnings do not, by themselves, eliminate any danger. The instructions and warnings they give are no substitutes for proper accident prevention measures.

WARNING: Be sure to read and understand all safety instructions in this Operator's Manual, including all safety alert symbols such as "DANGER", "WARNING", and "CAUTION" before using this tool. Failure to follow all instructions listed below may result in electric shock, fire, and/or serious personal injury.

DAMAGE PREVENTION AND INFORMATION MESSAGES

These inform the user of important information and/or instructions that could lead to equipment or other property damage if they are not followed. Each message is preceded by the word "NOTICE", as in the example below:

NOTICE: Equipment and/or property damage may result if these instructions are not followed.



WARNING: The operation of any power tools can result in foreign objects being thrown into your eyes, which can result in severe eye damage. Before beginning power tool operation, always wear safety goggles or safety glasses with side shields and a full face shield when needed. We recommend a Wide Vision Safety Mask for use over eyeglasses or standard safety glasses with side shields.

SAFETY INSTRUCTIONS

This page depicts and describes safety symbols that may appear on this product. Read, understand, and follow all instructions on the machine before attempting to assemble and operate.

	Safety Alert	Precautions that involve your safety.
	Read Operator's Manual	To reduce the risk of injury, user must read the operator's manual.
	Wear Eye Protection	Always wear safety goggles or safety glasses with side shields and a full face shield when operating this product.
	Wear Ear Protection	Always wear ear protection when operating this product.
	Wear Head Protection	Wear an approved safety hard hat to protect your head.
	Wear Protective Gloves	Protect your hands with gloves when handling saw and saw chain. Heavy-duty, nonslip gloves improve your grip and protect your hands.
	Two Handed hold	Always use chainsaw two-handed
	Be Aware of Kickback	Beware of chainsaw kickback and avoid contact with bar tip
	Guide Bar	The information of guide bar.
	Noise	Sound pressure level

	Direct Current	Type or a characteristic of current
	Regulatory Compliance Mark	This product complies with applicable Australian standards.
IPX4	Ingress Protection Degree	Protection from splashing water
m ³ /h	Cubic Metre Per Hour	Air volume
m/s	Metre Per Second	Air velocity
kg	Kilogram	Weight
V	Volt	Voltage
min	Minutes	Time
N	Newton	Blowing force

When using an electrical appliance, basic precautions should always be followed, including the following:

GERAL POWER TOOL SAFETY WARNINGS

⚠ WARNING: Read all safety warnings, instructions, illustrations and specifications provided with this power tool. Failure to follow all instructions listed below may result in electric shock, fire and/or serious injury.

SAVE ALL WARNINGS AND INSTRUCTIONS FOR FUTURE REFERENCE.

The term “power tool” in the warnings refers to your mains- operated (corded) power tool or battery-operated (cordless) power tool.

WORK AREA SAFETY

- **Keep work area clean and well lit.** Cluttered or dark areas invite accidents.
- **Do not operate power tools in explosive atmospheres, such as in the presence of flammable liquids, gases or dust.** Power tools create sparks which may ignite the dust or fumes.
- **Keep children and bystanders away while operating a power tool.** Distractions can cause you to lose control.

ELECTRICAL SAFETY

- **Power tool plugs must match the outlet. Never modify the plug in any way. Do not use any adaptor plugs with earthed (grounded) power tools.** Unmodified plugs and matching outlets will reduce risk of electric shock
- **Avoid body contact with earthed or grounded surfaces, such as pipes, radiators, ranges and refrigerators.** There is an increased risk of electric shock if your body is earthed or grounded.
- **Do not expose power tools to rain or wet conditions.** Water entering a power tool will increase the risk of electric shock.
- **Do not abuse the cord. Never use the cord for carrying, pulling or unplugging the power tool. Keep cord away from heat, oil, sharp edges or moving parts.** Damaged or entangled cords increase the risk of electric shock.
- **When operating a power tool outdoors, use an extension cord suitable for outdoor use.** Use of a cord suitable for outdoor use reduces the risk of electric shock.
- **If operating a power tool in a damp location is unavoidable, use a Ground-fault circuit interrupter protected supply.** Use of GFCI reduces the risk of electric shock.

PERSONAL SAFETY

- **Stay alert, watch what you are doing and use common sense when operating a power tool. Do not use a power tool while you are tired or under the influence of drugs, alcohol medication.** A moment of inattention while operating power tools may result in serious personal injury.
- **Use personal protective equipment. Always wear eye protection.** Protective equipment such as a dust mask, non-skid safety shoes, hard hat or hearing protection used for appropriate conditions will reduce personal injuries.
- **Prevent unintentional starting. Ensure the switch is in the off-position before connecting to power source and/or battery pack, picking up or carrying the tool.** Carrying power tools with your finger on the switch or energizing power tools that have the switch on invites accidents.
- **Remove any adjusting key or wrench before turning the power tool on.** A wrench or a key left attached to a rotating part of the power tool may result in personal injury.

- **Do not overreach. Keep proper footing and balance at all times.** This enables better control of the power tool in unexpected situations.
- **Dress properly. Do not wear loose clothing or jewellery. Keep your hair, clothing and gloves away from moving parts.** Loose clothes, jewelry or long hair can be caught in moving parts.
- **If devices are provided for the connection of dust extraction and collection facilities, ensure these are connected and properly used.** Use of dust devices can reduce dust-related hazards.
- **Do not let familiarity gained from frequent use of tools allow you to become complacent and ignore tool safety principles.** A careless action can cause severe injury within a fraction of a second
- **Keep handles and grasping surfaces dry, clean and free from oil and grease.** Slippery handles and grasping surfaces may lead to unsafe handling and/or loss of control of the tool.

BATTERY TOOL USE AND CARE

POWER TOOL USE AND CARE

- **Do not force the power tool. Use the correct power tool for your application.** The correct power tool will do the job better and safer at the rate for which it was designed.
- **Do not use the power tool if the switch does not turn it on and off.** Any power tool that cannot be controlled with the switch is dangerous and must be repaired.
- **Disconnect the plug from the power source and/or the battery pack from the power tool before making any adjustments, changing accessories, or storing power tools.** Such preventive safety measures reduce the risk of starting the power tool accidentally.
- **Store idle power tools out of the reach of children and do not allow persons unfamiliar with the power tool or these instructions to operate the power tool.** Power tools are dangerous in the hands of untrained users.
- **Maintain power tools and accessories. Check for misalignment or binding of moving parts, breakage of parts and any other condition that may affect the power tool's operation. If damaged, have the power tool repaired before use.** Many accidents are caused by poorly maintained power tools.
- **Keep cutting tools sharp and clean.** Properly maintained cutting tools with sharp cutting edges are less likely to bind and are easier to control.
- **Use the power tool, accessories and tool bits etc. in accordance with these instructions, taking into account the working conditions and the work to be performed.** Use of the power tool for operations different from those intended could result in a hazardous situation.
- **Recharge only with the charger specified by the manufacturer.** A charger that is suitable for one type of battery pack may create a risk of fire when used with another battery pack.
- **Use power tools only with specifically designated battery packs.** Use of any other battery packs may create a risk of injury and fire.
- **When battery pack is not in use, keep it away from other metal objects, like paper clips, coins, keys, nails, screws or other small metal objects, that can make a connection from one terminal to another.** Shorting the battery terminals together may cause burns or a fire.
- **Under abusive conditions, liquid may be ejected from the battery; avoid contact. If contact accidentally occurs, flush with water. If liquid contacts eyes, additionally seek medical help.** Liquid ejected from the battery may cause irritation or burns.
- **Do not use a battery pack or tool that is damaged or modified.** Damaged or modified batteries may exhibit unpredictable behavior resulting in fire, explosion or risk of injury.
- **Do not expose a battery pack or tool to fire or excessive temperature.** Exposure to fire or temperature above 130°C may cause explosion.
- **Follow all charging instructions and do not charge the battery pack or tool outside the temperature range specified in the instructions.** Charging improperly or at temperatures outside the specified range may damage the battery and increase the risk of fire.

SERVICE

CHAINSAW SAFETY WARNINGS

- **Keep all parts of the body away from the saw chain when the chainsaw is operating. Before you start**

the chainsaw, make sure the saw chain is not contacting anything. A moment of inattention while operating chainsaws may cause entanglement of your clothing or body with the chain.

- **Always hold the chainsaw with your right hand on the rear handle and your left hand on the front handle.** Holding the chainsaw with a reversed hand configuration increases the risk of personal injury and should never be done.
- **Hold the chainsaw by insulated gripping surfaces only, because the saw chain may contact hidden wiring.** Saw chains contacting a “live” wire may make exposed metal parts of the power tool “live” and could give the operator an electric shock.
- **Wear eye protection. Further protective equipment for hearing, head, hands, legs and feet is recommended.** Adequate protective clothing will reduce personal injury by flying debris or accidental contact with the saw chain.
- **Do not operate a chainsaw on a ladder, from a rooftop, or any unstable support.** Operation of a chainsaw in this manner could result in serious personal injury.
- **Do not operate a chainsaw in a tree unless you have been specifically trained to do so.** Operation of a chainsaw in a tree without proper training could increase the risk of serious personal injury.
- **Always keep proper footing and operate the chainsaw only when standing on fixed, secure and level surface.** Slippery or unstable surfaces such as ladders may cause a loss of balance or control of the chainsaw.
- **When cutting a limb that is under tension be alert for spring back.** When the tension in the wood fibers is released the spring loaded limb may strike the operator and/or throw the chainsaw out of control.
- **Use extreme caution when cutting brush and saplings.** The slender material may catch the saw chain and be whipped toward you or pull you off balance.
- **Carry the chainsaw by the front handle with the chainsaw switched off and away from your body. When transporting or storing the chainsaw always fit the guide bar cover.** Proper handling of the chainsaw will reduce the likelihood of accidental contact with the moving saw chain.
- **Follow instructions for lubricating, chain tensioning and changing accessories.** Improperly tensioned or lubricated chain may either break or increase the chance for kickback.

- **Cut wood only. Do not use chainsaw for purposes not intended. For example: do not use chainsaw for cutting plastic, masonry or non-wood building materials.** Use of the chainsaw for operations different than intended could result in a hazardous situation.
- **This chainsaw is not intended for tree felling.** Use of the chainsaw for operations different than intended could result in serious injury to the operator or bystanders.
- **Follow all instructions when clearing jammed material, storing or servicing the chainsaw.** Make sure the switch is off and the battery pack is removed. Unexpected actuation of the chainsaw while clearing jammed material or servicing may result in serious personal injury.

CAUSES AND OPERATOR PREVENTION OF KICKBACK

Kickback may occur when the nose or tip of the guide bar touches an object, or when the wood closes in and pinches the saw chain in the cut (Fig. B).

Tip contact in some cases may cause a sudden reverse reaction, kicking the guide bar up and back towards the operator (Fig. C).

Pinching the saw chain along the top of the guide bar may push the guide bar rapidly back towards the operator (Fig. D).

Either of these reactions may cause you to lose control of the saw which could result in serious personal injury. Do not rely exclusively upon the safety devices built into your saw.

As a chainsaw user, you should take several steps to keep your cutting jobs free from accident or injury.

Kickback is the result of tool misuse and/or incorrect operating procedures or conditions and can be avoided by taking proper precautions as given below:

- **Maintain a firm grip, with thumbs and fingers encircling the chainsaw handles, with both hands on the saw and position your body and arm to allow you to resist kickback forces (Fig. E).** Kickback forces can be controlled by the operator, if proper precautions are taken. Do not let go of the chainsaw.
- **Do not overreach and do not cut above shoulder height.** This helps prevent unintended tip contact and enables better control of the chainsaw in unexpected situations.

- **Only use replacement bars and chains specified by the manufacturer.** Incorrect replacement bars and chains may cause chain breakage and/or kickback.
- **Follow the manufacturer's sharpening and maintenance instructions for the saw chain.** Decreasing the depth gauge height can lead to increased kickback.
- **Make sure that the area in which you are cutting is free from obstructions.** Do not let the nose of the guide bar contact a log, branch, fence, or any other obstruction that could be hit while you are operating the saw.
- **Always cut with the unit running at full speed.** Fully squeeze the switch trigger and maintain cutting speed.
- **With a basic understanding of kickback, you can reduce or eliminate the element of surprise.** Sudden surprise contributes to accidents.
- **Keep proper footing and balance at all times.**
- **Push and Pull** – The reaction force is always opposite to the direction the chain is moving where wood contact is made. Thus, the operator must be ready to control the PULL when cutting on the bottom edge of the bar, and the PUSH when cutting along the top edge (Fig. F).

KICKBACK SAFETY DEVICES ON THIS CHAINSAW CHAIN BRAKE

The chainsaw comes equipped with a chain brake, which stops both the motor and the motion of the chain when kickback occurs. The chain brake can be activated by the forward motion of the chain kickback brake paddle as the saw rotates backward during kickback; it can also be activated by the inertial forces generated during rapid pushback.

⚠ WARNING: Never modify or attempt to disable the chain brake.

Make sure that the chain brake is working properly before using the chainsaw. The chain kickback brake paddle should move back and forth easily.

To test the operation of the chain brake, perform the following steps (Fig. G):

- Place the chainsaw on a flat bare surface and make sure no objects or obstructions that could come in contact with the bar and chain are in the immediate vicinity.
 - Disengage the chain brake by pulling the chain kickback brake paddle towards the front handle.
 - Start the chainsaw.
- Push the chain kickback brake paddle towards the front of the saw. A properly functioning hand brake will stop the movement of the chain immediately. If the chain brake is not working properly, do not use the chainsaw until it has been repaired by a qualified service technician.

⚠ WARNING: Confirm that the chain brake works properly before each use.

⚠ WARNING: If the chain brake is clogged with wood chips, the function of the chain brake may deteriorate. Always keep the device clean.

LOW KICKBACK SAW CHAIN

The rakers (depth gauges) ahead of each cutter can minimize the force of a kickback reaction by preventing the cutters from digging in too deeply at the kickback zone. Only use a replacement chain that is equivalent to the original chain or has been certified one.

⚠ CAUTION: As saw chains are sharpened during their useful life, they lose some of the low kickback qualities and extra caution should be used.

ADDITIONAL WARNINGS

- **A chainsaw is intended for two-handed use.** Serious injury to the operator, helpers, and/or bystanders can result from one-handed operation.
- **Avoid unintentional contact with the stationary saw chain or guide bar rails.** These can be very sharp. Always wear gloves and long pants or chaps when handling the chainsaw, saw chain, or guide bar.
- **Never operate a chainsaw that is damaged or improperly adjusted or that is not completely and securely assembled.** Be sure that the saw chain stops moving when the trigger switch is released.
- **Inspect the work piece for nails, wire, or other foreign objects prior to cutting.**
- **When bucking, secure the work piece prior to cutting. When felling or pruning, identify and secure hazardous branches.**
- **Aggressive or abusive cutting or misuse of the chainsaw can cause premature bar, chain, and/or sprocket wear, as well as broken chain or bar, leading to kickback, chain throw or the ejection of material.**
- **Never use the guide bar as a lever.** A bent guide bar can cause premature bar, chain, and/or sprocket wear, as well as a broken chain or bar, leading to kickback, chain throw or the ejection of material.

- Cut only one work piece at a time.
- Use only with battery packs and chargers listed below.

BATTERY PACK	CHARGER
BA1400, BA1400T	CH2100E, CH5500E CH7000E, CH7000E-T

- Do not charge the battery pack in rain or in wet locations.
- Plan the work, ensuring an obstacle-free work area and, in the case of felling, at least one escape path from the falling tree.
- When felling, keep bystanders at least two tree lengths away.
- If situations occur which are not covered in this manual, use care and good judgment. Contact EGO Customer Service for assistance.

GUIDE BAR

This saw comes equipped with a guide bar that has a small radius nose. Small radius noses generally have less potential for kickback. When replacing the guide bar, be sure to order the bar listed in this manual.

SAVE THESE INSTRUCTIONS!

SPECIFICATIONS

Rated Voltage	56V
Max. Chain Speed	20 m/s
Chain Pitch	3/8" (9.5mm) LP
Chain Gauge	1.1mm
Guide Bar Length	30cm
Saw Chain Model	AC1204
Guide Bar Model(recommended)	AG1200
Chain Oil Tank Capacity	150 ml
Weight(without battery , saw chain and guide bar)	2.15 kg
Recommended Operating Temperature	-15°C-40°C
Recommended Storage Temperature	-20°C-70°C
Recommended Charging Temperature	5°C-40°C

PACKING LIST

PART NAME	QUANTITY
Chainsaw	1
Chain sheath	1
Operator's manual	1

DESCRIPTION

KNOW YOUR CHAINSAW (Fig. A)

1. Guide Bar
2. Saw Chain
3. Chain-kickback Brake Paddle
4. Rear Handle
5. Front Handle
6. Oil-inspection Window
7. Oil Tank Cap
8. Locking Tongue
9. Trigger Switch
10. Battery-release Button
11. Side Cover
12. Chain-tensioning Knob
13. Side-cover Knob
14. Lubricating Hole
15. Chain Sheath
16. Lanyard Hanger

ASSEMBLY

ASSEMBLING/REPLACING THE BAR AND CHAIN

⚠ WARNING: Before performing any assembling or maintenance, make sure that the battery pack is removed. Failure to heed this warning could result in serious personal injury.

⚠ WARNING: Adjust the chain-kickback brake paddle in the braking position before assembly.

⚠ WARNING: Always wear gloves when handling the bar and chain; these components are sharp and may contain burrs.

1. Position the chainsaw on its side with the side cover facing upwards.

2. Remove the side cover by turning the side-cover knob counterclockwise. Clean the side cover with a dry cloth (Fig. H).
3. Remove the worn bar and chain from the mounting surface.

NOTICE: This is a good time to inspect the drive sprocket for excessive wear or damage.

4. Lay the new saw chain in a loop on a flat surface and straighten any kinks (Fig. I).
5. Place the chain drive links into the guide bar groove. Position the chain so there is a loop at the back of the guide bar (Fig. J).
6. Hold the chain in position on the guide bar and place the loop around the drive sprocket of the saw.

NOTICE: When looping the saw chain onto the guide bar, make sure that after mounting the guide bar onto the saw, the cutter orientation matches the cutter icon and rotation direction arrow on the housing of the saw (Fig. K1). If they face in opposite directions, reassemble the saw chain onto the guide bar with the cutters facing the same direction (Fig. K2).

7. Place the guide bar on the mounting surface by sliding the guide-bar slot over the alignment flanges. Make sure that the guide bar is correctly positioned over the fastening bolt.

NOTICE: During assembly and maintenance, the metal plate underneath the guide bar (Fig. L) may pop up. If this happens, clean the gap between this metal piece and the housing thoroughly and push the metal plate back so it is **flush against the housing**. Failure to clean and properly place the metal plate will cause the guide bar misalignment.

8. Attach the side cover to the housing so that the holes/pins and fastening bolt/thread hole are aligned with each other properly (Fig. M). Lightly tighten the side-cover knob by turning it clockwise. The bar must be free to move for tension adjustment.

NOTICE: To extend the guide-bar life, invert the bar occasionally.

⚠ WARNING: The saw chain must be properly tensioned before using. Tension the chain by following instructions in the chapter “**ADJUSTING THE CHAIN TENSION**” in the next section.

ADJUSTING THE CHAIN TENSION

- Stop the motor and remove the battery pack before adjusting the chain tension. Turn the chain-tensioning knob clockwise or counterclockwise to adjust chain tension (Fig. H) until the chain seats snugly against the guide bar with the drive links in the guide bar groove.
- A cold chain is correctly tensioned when there is no slack on the underside of the guide bar and the chain is snug, but it can be turned by hand without binding. The chain must be re-tensioned whenever the flats on the drive links do not sit in the bar groove.
- During normal saw operation, the temperature the chain will increase. The drive links of a correctly tensioned warm chain will hang approximately 1-2 mm out of the bar groove (Fig. N).

NOTICE: New chains tend to stretch; check chain tension frequently and tension as required.

NOTICE: A chain tensioned while it is warm may be too tight upon cooling. Check the cold tension before next use.

OPERATION

⚠ WARNING: Do not allow familiarity with this product to make you careless. Remember that a careless fraction of a second is sufficient to inflict serious injury.

⚠ WARNING: Do not use any attachments or accessories not recommended by the manufacturer of this product. The use of attachments or accessories not recommended can result in serious personal injury.

⚠ WARNING: To prevent accidental starting that could cause serious personal injury, always remove the battery pack from the tool when assembling parts, making adjustments, cleaning, or when not in use.

Before each use, inspect the entire product for damaged, missing, or loose parts, such as screws, nuts, bolts, caps, etc. Securely tighten all fasteners and caps and do not operate this product until all missing or damaged parts are replaced.

APPLICATIONS

You may use this product for basic in-tree cutting applications.

⚠ WARNING: Do not operate this chainsaw in a tree unless you have been specifically trained to do so. Operation of a chainsaw in a tree without proper training could increase the risk of serious personal injury.

NOTICE: The machine is to be used only for its prescribed purposes. Any other use is deemed to be a case of misuse.

FILLING BAR AND CHAIN LUBRICANT

⚠ WARNING: Do not smoke or bring any fire or flame near the oil or the chainsaw. Oil may spill and cause a fire.

NOTICE: The chainsaw is not filled with oil at the time of purchase. It is essential to fill the tank with oil before use. The chain is automatically lubricated with chain oil during operation, if there is sufficient oil in the oil tank.

1. Position the chainsaw on its side with the tank cap facing upwards.
2. Clean the oil tank cap and the area around it to ensure that no dirt falls into the oil tank.
3. Lift up the semicircular plate and rotate the oil tank cap counterclockwise to remove it (Fig. O).
4. Carefully pour the bar and chain oil into the tank. Fill to the bottom of the fill neck.
5. Wipe off any excessive oil and replace the cap.

NOTICE: Check the oil level frequently and fill when the oil level falls below the minimum line. Never operate the chainsaw if the oil is not visible.

USING THE LANYARD EYELET (Fig. O)

⚠ WARNING: Always cover the saw chain and guide bar with chain sheath when hanging the chainsaw on a tool belt. Saw chain is sharp and may cause serious injuries.

⚠ WARNING: Make sure the lanyard is sufficiently strong to support the combined weight of the chainsaw and the battery pack. Serious injuries and property damage could result if the chainsaw falls.

ATTACHING/DETACHING THE BATTERY PACK

Fully charge before first use.

To Attach

Align the battery ribs with the mounting slots and press the battery pack down until you hear a “click” (Fig. P).

To Detach

Depress the battery-release button and pull the battery pack out (Fig. Q).

⚠ WARNING: To keep comfortable balance during cutting, please use only with the battery pack BA1400/BA1400T.

STARTING/STOPPING THE Chainsaw

NOTICE: Before starting the chainsaw, check for the oil level, chain tension, saw teeth sharpness and properly working kickback brake paddle. Besides, balanced footing and proper distance away from the ground are needed.

To Start (Fig. R)

1. Pull the chain-kickback brake paddle towards the front handle to the operating position (Fig. R).
2. Firmly grasp the front handle with the **left** hand and the rear handle with the **right** hand.

⚠ WARNING: To avoid injury, always use the chainsaw with the right hand grasping the gripping area of the rear handle (Fig. S).

3. Move the locking tongue forward and then press the trigger switch to start the saw (Fig. S).
4. Release the locking tongue and continue to squeeze the trigger switch for continued operation.
5. The further the trigger switch is depressed, the greater the chain speed. Adjust the speed to suit the task at hand.

⚠ WARNING: Do not attempt to start the saw when the saw chain is in a cut.

To Stop

1. Move the chainsaw away from cutting area, and then release the trigger switch to stop the chainsaw.
2. Push the chain-kickback brake paddle forward to the brake position to engage the chain brake (Fig. R).

⚠ WARNING: Always remove the battery pack from the machine during work breaks and after finishing work.

PROPER GRIP ON HANDLES (Fig. T)

- Wear non-slip gloves for maximum grip and protection.
- With the saw on a firm, flat surface, hold the saw firmly with both hands.
- Always grasp the front handle with the left hand and the rear handle with the right hand.
- The fingers should encircle the handle, with the thumb wrapped under the front handle.

⚠ WARNING: Never use a left-handed (cross-handed) grip, or any stance which would place your body or arm across the chain line.

⚠ WARNING: Do not operate the trigger switch with your left hand and hold the front handle with your right hand. Never allow any part of your body to be in the chain line while operating a chainsaw (Fig. U1).

PROPER CUTTING STANCE (FIG. U2)

- Both feet should be on solid ground, with weight evenly spread between them.
- The left arm should be straight, with the elbow locked. This helps to withstand the forces generated by kickback.
- Your body should always be to the left of the chain line.

COMMON CUTTING TECHNIQUES

⚠ WARNING: Always be sure of your footing and hold the chainsaw firmly with both hands while the motor is running.

⚠ WARNING: When the saw chain is stopped due to pinching during cutting, release the trigger switch; remove the saw chain and guide bar from the wood, then restart the chainsaw.

⚠ WARNING: Do not pull the saw chain with hand when it is bound by the sawdust. Serious injury could result if the chainsaw starts accidentally. Press the saw chain against the wood, move the chainsaw back and forth to discharge the debris. Always remove the battery pack before cleaning. Wear heavy protective gloves when handling the saw chain.

⚠ WARNING: Never start the chainsaw when it is in contact with the wood. Always allow the chainsaw reach full speed before applying the saw to the wood.

⚠ WARNING: This top-handle chainsaw is not intended to be used on the ground, therefore this manual does not contain instructions for felling trees, limbing and bucking trees.

⚠ WARNING: These in-tree instructions apply to this top-handle chainsaw, designed exclusively for in-tree cutting applications by certified tree service professionals specifically trained to do so.

⚠ WARNING: Blocking can result in injury. It should only be performed by a trained person.

⚠ WARNING: First time users should practice cutting logs on a saw horse or log cradle.

⚠ WARNING: Do not work in trees with high wind conditions.

⚠ WARNING: Ensure all bystanders are clear of the fall area before starting operation.

⚠ WARNING: Always keep yourself and your equipment clear of the material being removed.

⚠ CAUTION: Be sure battery is fully charged before working in a tree.

Pruning (Fig. V)

Follow the steps below to prevent damage to tree or shrub bark. Do not use a back-and-forth sawing motion.

1. Make a shallow first cut (1/3 of the limb diameter) on the underside of the limb, close to the main limb or trunk.
2. Make a second cut from the top side of the limb, outboard from the first cut. Continue the cut through the limb until the limb separates from the tree. Be prepared to balance the weight of the tool, and ensure you are clear of it before completing the cut.
3. Make a final cut close to trunk.

Blocking

Before blocking, remove loose bark, nails, staples, and wire from the tree where the blocking cuts are to be made.

Notching undercut

Make the notch 1/4 the diameter of the tree, perpendicular to the direction of falls as Fig. W shown. Make the lower horizontal notching cut first. This will help to avoid pinching either the saw chain or the guide bar when the second notch is being made.

Back cut

- Make the back cut the same height as the horizontal notching cut as Fig. W shown. Keep the back cut parallel to the horizontal notching cut. Make the back cut so enough wood is left to act as a hinge. The hinge wood keeps the tree from twisting and falling in the wrong direction. Do not cut through the hinge.
- As the back cut gets close to the hinge, the tree should begin to fall. If there is any chance that the tree may not fall in desired direction or it may rock back and bind the saw chain, stop cutting before the back cut is complete and use wedges of wood, plastic or aluminium to open the cut and drop the tree along the desired line of fall.
- When the tree block begins to fall remove the chainsaw from the cut, stop the motor, and activate the chain brake. Be alert for overhead limbs falling and watch your footing.

MAINTENANCE

⚠ WARNING: When servicing, use only identical replacement parts. Use of any other parts may create a hazard or cause product damage. To ensure safety and reliability, all repairs should be performed by a qualified service technician.

⚠ WARNING: To avoid serious personal injury, always remove the battery pack from the product before inspecting, cleaning, or performing maintenance. A battery operated tool with the battery pack inserted is always on and can start accidentally.

⚠ WARNING: When cleaning the chainsaw, DO NOT immerse it in water or other liquids.

⚠ WARNING: Do not at any time let brake fluids, petrol, petroleum-based products, penetrating oils, etc., come in contact with plastic parts. Chemicals can damage, weaken, or destroy plastic, which may result in serious personal injury.

CLEANING

- After each use, clean debris from the chain and guide bar with a soft brush. Wipe the chainsaw surface with a clean cloth moistened with a mild soap solution.
- Remove the side cover, and then use a soft brush to remove debris from the guide bar, saw chain, sprocket and side cover.
- Always clean out wood chips, saw dust, and dirt from the guide bar groove when replacing the saw chain.

GUIDE BAR MAINTENANCE

When the guide bar shows signs of wear, disassemble it from the chainsaw power head and reverse it for reassembly (Fig. X1). This way the wear will be distributed to maximize the guide bar life.

The bar should be cleaned every day of use and checked for wear and damage. Feathering or burring of the bar rails is a normal process of bar wear. Such faults should be smoothed with a file as soon as they occur. A bar with any of the following faults should be replaced.

- Wear inside the bar rails which permits the chain to lay over sideways.
- Bent guide bar.
- Cracked or broken rails.
- Spread rails.

In addition, the guide bar has a sprocket at its tip (Fig. X2). The sprocket must be lubricated weekly with a grease syringe to extend the guide bar life. Use a grease syringe to lubricate weekly with chain oil by means of the lubricating hole (Fig. X3). Turn the guide bar and check that the lubrication holes and chain groove are free from impurities.

TRANSPORTING AND STORING

- Do not store or transport the chainsaw when it is running. Always remove the battery pack before storing or transporting.
- Always place the chain sheath on the guide bar and chain before storing or transporting the chainsaw. Use caution to avoid the sharp teeth of the chain.
- Always carry the product by its front handle.
- Protect the product from any heavy impact or strong vibrations which may occur during transportation in vehicles.
- Clean the chainsaw thoroughly and empty the oil tank before storing. Store the chainsaw indoors, in a dry place that is locked and/or inaccessible to children.
- Keep away from corrosive agents such as garden chemicals and de-icing salts.

PROTECTING THE ENVIRONMENT



Do not dispose of electrical appliances as unsorted municipal waste, use separate collection facilities.

Contact your local government for information regarding the collection systems available.

If electrical appliances are disposed of in landfills or dumps, hazardous substances can leak into the groundwater and get into the food chain, damaging your health and well-being.

TROUBLESHOOTING

⚠ WARNING: Always protect your hands by wearing heavy gloves when performing any maintenance on the saw chain. Always remove the battery pack when servicing or transporting the chainsaw.

PROBLEM	CAUSE	SOLUTION
Motor does not run.	<ul style="list-style-type: none"> ■ The battery pack is not attached to the chainsaw. ■ No electrical contact between the saw and battery pack. ■ The battery pack charge is depleted. ■ The battery pack or chainsaw is too hot. ■ The locking tongue is not depressed before pressing the trigger switch. ■ Chain brake is engaged. ■ Saw chain is bound in the wood. ■ Debris in bar groove. ■ Debris in side cover. ■ A 4.0Ah or higher Ah battery pack is used. 	<ul style="list-style-type: none"> ■ Attach the battery pack to the chainsaw. ■ Remove battery pack, check contacts and reinstall the battery pack. ■ Charge the battery pack. ■ Allow the battery pack or chainsaw to cool until the temperature drops to the recommended operating temperature range. ■ Press down the locking tongue and hold it, then depress the trigger switch to turn on the chainsaw. ■ Pull the chain-kickback brake paddle backward toward the front handle, to the operating position. ■ Release the trigger switch; remove the saw chain and guide bar from the wood, then restart the chainsaw. ■ Press the saw chain against the wood, move the chainsaw back and forth to discharge the debris. ■ Remove battery pack, then remove side cover and clean out debris. ■ Use only with EGO 2.5 Ah battery packs BA1400 and BA1400T.
Chainsaw stops unexpectedly during operation.	<ul style="list-style-type: none"> ■ The chainsaw is overloaded. ■ The battery pack or chainsaw is too hot. ■ Saw chain is bound in the wood. 	<ul style="list-style-type: none"> ■ Decrease the load. ■ Allow the battery pack or chainsaw to cool until the temperature drops to the recommended operating temperature range. ■ Release the trigger switch; remove the saw chain and guide bar from the wood, then restart the chainsaw.
Motor runs, but chain does not rotate.	<ul style="list-style-type: none"> ■ Chain does not engage drive sprocket. 	<ul style="list-style-type: none"> ■ Remove the battery pack and reinstall the chain, making sure that the drive links on the chain are fully seated on the sprocket.
Chain brake does not engage.	<ul style="list-style-type: none"> ■ Debris preventing full movement of the chain-kickback brake paddle. ■ Possible chain brake malfunction. 	<ul style="list-style-type: none"> ■ Clean debris from the external chain brake mechanism. ■ Stop using the chainsaw immediately! Contact EGO Customer Service for repair.

PROBLEM	CAUSE	SOLUTION
Chainsaw does not cut properly.	<ul style="list-style-type: none"> ■ Insufficient chain tension. ■ Dull chain. ■ Chain installed backwards. ■ Worn chain. ■ Dry or excessively stretched chain. ■ Chain not in bar groove. 	<ul style="list-style-type: none"> ■ Readjust the chain tension, following the section: “ADJUSTING THE CHAIN TENSION”. ■ Sharpen the chain. ■ Reinstall the saw chain, following the section “ASSEMBLING/REPLACING THE BAR AND CHAIN”. ■ Replace the chain, following the section: “ASSEMBLING/REPLACING THE BAR AND CHAIN”. ■ Check the oil level. Refill the oil tank if necessary. ■ Reinstall the saw chain, following the section: “ASSEMBLING/REPLACING THE BAR AND CHAIN”.
Chain becomes loose or drops off the guide bar during normal use.	<ul style="list-style-type: none"> ■ The chain will become loose as the temperature of the chain increases during normal saw operation. ■ Chain does not engage drive sprocket. 	<ul style="list-style-type: none"> ■ Tighten the chain tension, following the section “ADJUSTING THE CHAIN TENSION”. ■ Reinstall the saw chain, following the section: “ASSEMBLING/REPLACING THE BAR AND CHAIN”.
Bar and chain running hot and smoking.	<ul style="list-style-type: none"> ■ Check chain tension for over-tightened condition. ■ Chain oil tank is empty. ■ Debris in guide bar groove. 	<ul style="list-style-type: none"> ■ Re-tension the saw chain following the section “ADJUSTING THE CHAIN TENSION”. ■ Fill the tank with bar and chain lubricant. ■ Press the saw chain against the wood, move the chainsaw back and forth to discharge the debris.

WARRANTY

EGO WARRANTY POLICY

For full warranty terms and conditions, warranty service or to make a claim, please visit our website egopowerplus.com.au/warranty-policy.

Also see full warranty details & warranty table on the ‘NEED HELP?’ flyer contained within this product.

Alternatively you can contact EGO customer service via the following:

Australia

Address: Chervon Australia Pty Ltd, Unit 14, 5 Kelleets Rd, Rowville, VIC, 3178.

Phone: 1300 000 346

Email: support@egopowerplus.com.au

New Zealand

Address: Chervon New Zealand Subsidiary Ltd, 4th Floor, Smith & Caughey Building, 253 Queen St, Auckland, 1141.

Phone: 0508 000 346

Email: support@egopowerplus.co.nz

