

EGOTM COMMERCIAL

OPERATING MANUAL REPLACEMENT LINE TRIMMER HEAD MODEL NUMBER AH4500

This Replacement Line Trimmer Head is exclusively compatible with EGO COMMERCIAL Line Trimmer STX4500 and Brushcutter BCX4500.

⚠ DANGER: If the head loosens after it is fixed in position, replace it immediately. Never use a trimmer with a loose cutting attachment. Replace a cracked, damaged or worn out cutting head immediately, even if damage is limited to superficial cracks. Such attachments may shatter at high speed and cause serious injury.

⚠ WARNING: Always remove the battery pack from the product when you are assembling parts, making adjustments, cleaning, or when the product is not in use.

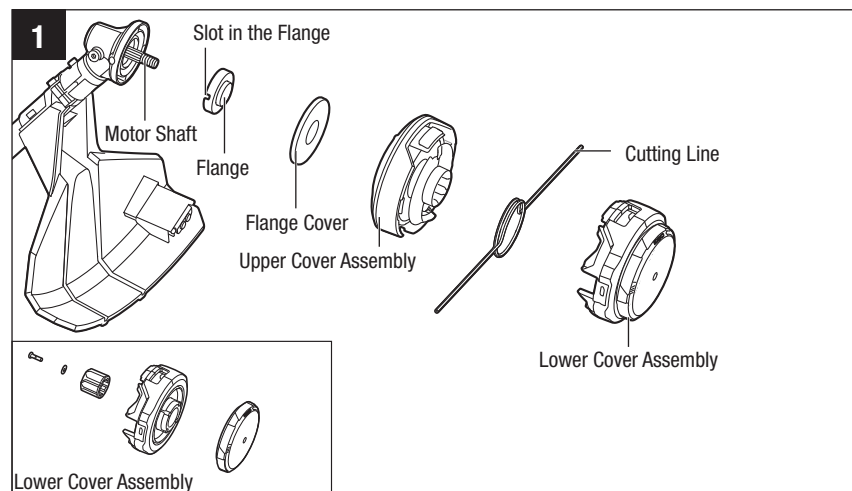

REMOVE THE TRIMMER HEAD

1. Remove the battery pack from the line trimmer.
2. Rotate the trimmer head to align the slot in the flange with the shaft-locking hole in the gear case and insert a hex key into the aligned holes to act as a stabilizer.
3. Wear gloves. Loosen the trimmer head **CLOCKWISE** (Fig. 2) until it can be removed from the shaft.

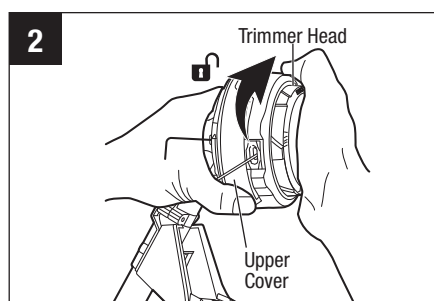

INSTALL THE NEW TRIMMER HEAD

1. Before installing the new trimmer head, make sure that the inner flange and flange cover are located correctly on the motor shaft as shown in Fig. 3.
2. Take out the new trimmer head and open it. Align the motor shaft with the screw hole of trimmer head, and then pre-tighten the trimmer head onto the shaft **COUNTERCLOCKWISE**.
3. Rotate the trimmer head to align the slot in the flange with the shaft locking hole in the gear case and insert the hex key into the aligned holes to act as a stabilizer.
4. Wear gloves. Securely tighten the trimmer head onto the shaft **COUNTERCLOCKWISE** (Fig. 4).

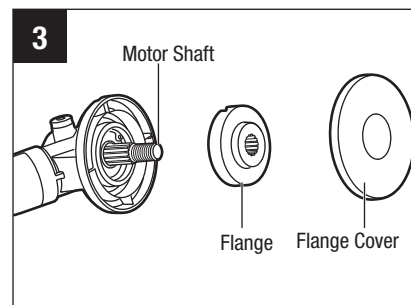

LINE REPLACEMENT

NOTICE: Only use the nylon cutting line of 2.7 mm diameter.

⚠ WARNING: Never use metal-reinforced line, wire, or rope, etc. These can break off and become dangerous projectiles.

1. Remove battery pack.
2. Remove the remaining cutting line, if necessary. Simply pull it out by hand.
3. Cut one piece of cutting line 6 m long. Insert the line into the eyelet (Fig. 5) and push the line until the end of the line comes out of the opposite eyelet. Pull the line from the other side until equal lengths of the line appear on both sides of the trimmer head.
4. Press and rotate lower cover assembly in the direction indicated by the arrow to wind the cutting line onto the spool until approximately 15 cm of line is showing on each side (Fig. 6).
5. Push the lower cover assembly down while pulling on the lines to manually advance the line and to check for proper assembly of the trimmer head.

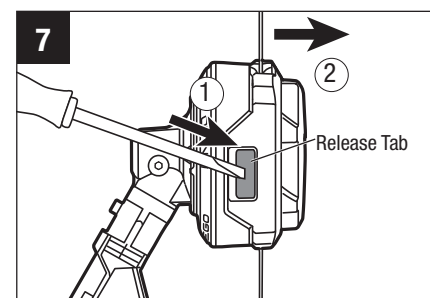
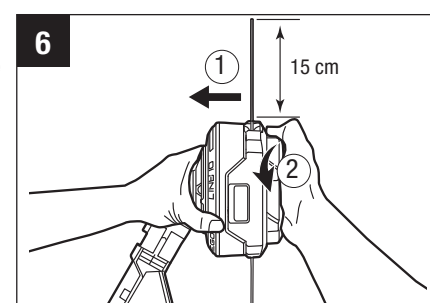
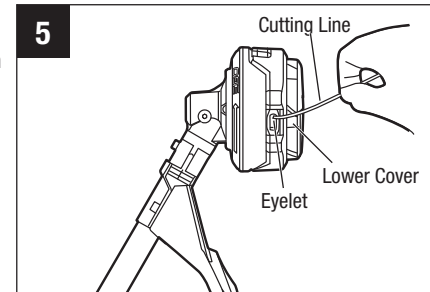
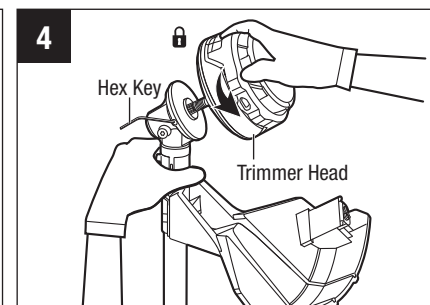

RELOADING THE CUTTING LINE

When the cutting line breaks from the eyelet or the cutting line is not released when the trimmer head is tapped, follow the steps below:

1. Remove the battery pack from the line trimmer.
2. Press two release tabs on the trimmer head and remove the lower cover assembly of the trimmer head by pulling it straight out (Fig. 7&8).
3. Remove the cutting line from the spool.
4. Make sure the spring is in its original position in the lower cover assembly.
5. With one hand holding the trimmer, use another hand to grasp the lower cover assembly and align the slots in the lower cover assembly with the release tabs. Press the lower cover assembly until it snaps into place, at which time you will hear a distinct click sound (Fig. 9).
6. Following the instructions in "**LINE REPLACEMENT**" to reload the cutting line.

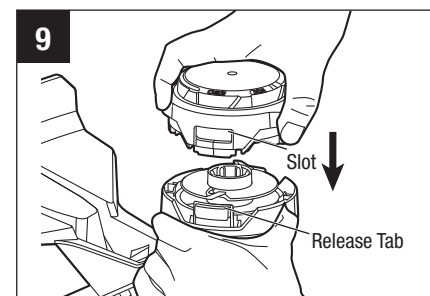
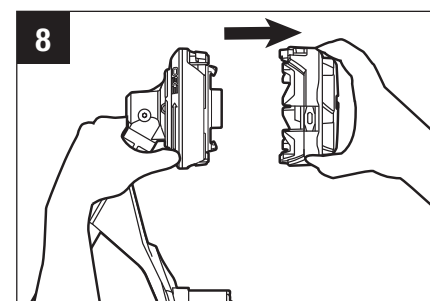

⚠ WARNING: Make sure that the release tabs on the spool retainer snap into place or the spool assembly will come out during operation, which may result in serious personal injury.