

# EGO™

POWER<sup>+</sup> CHARGER

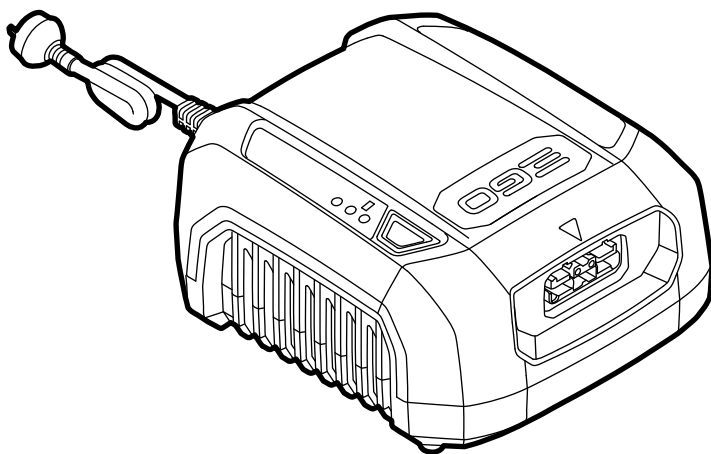

## OPERATOR'S MANUAL

# 56 VOLT CHARGER

MODEL NUMBER CHX5500E

**⚠ WARNING:** To reduce the risk of injury, the user must read and understand the Operator's Manual before using this product. Save these instructions for future reference.

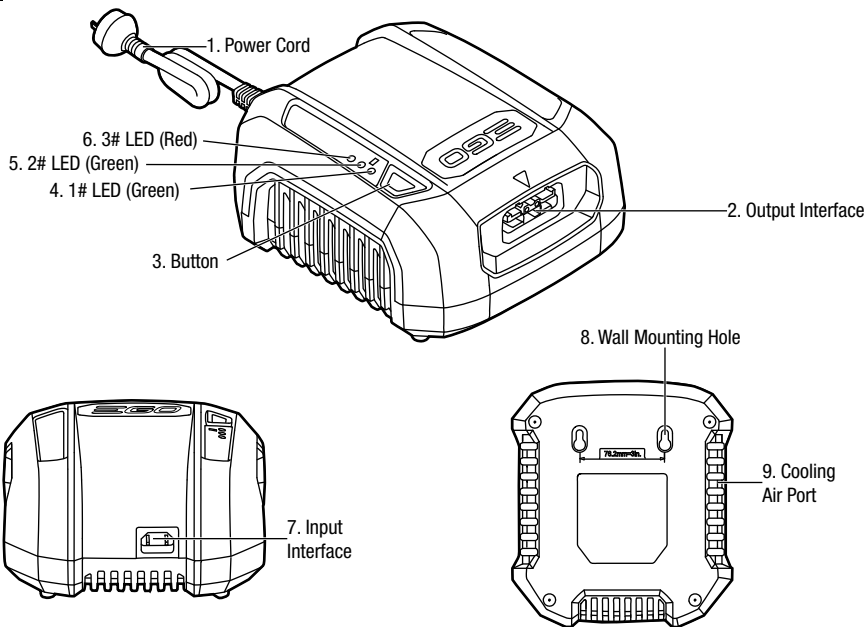
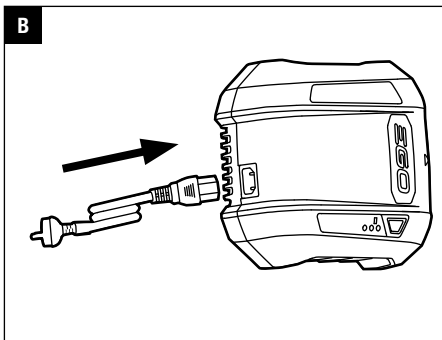
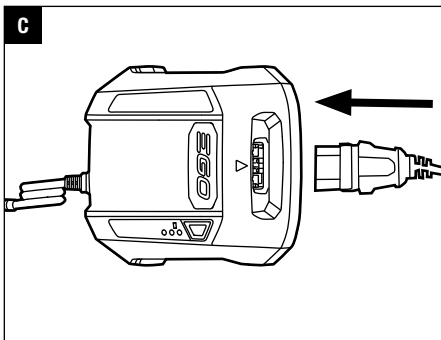
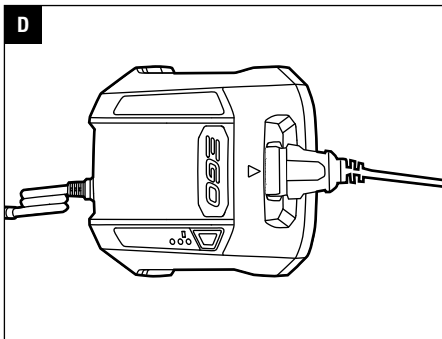
**A****B****C****D**

## READ ALL INSTRUCTIONS!



### READ OPERATOR'S MANUAL

**Notice:** These instructions shall also be available in an alternative format, e.g. on a website.

**⚠ Residual risk!** People with electronic devices, such as pacemakers, should consult their physician(s) before using this product. Operation of electrical equipment in close proximity to a heart pacemaker could cause interference or failure of the pacemaker.

**⚠ WARNING:** To ensure safety and reliability, all repairs should be performed by a qualified service technician.

**⚠ WARNING:** This appliance can be used by children aged from 8 years and above and persons with reduced physical, sensory or mental capabilities or lack of experience and knowledge if they have been given supervision or instruction concerning use of the appliance in a safe way and understand the hazards involved. Children shall not play with the appliance. Cleaning and user maintenance shall not be made by children without supervision.

## SAFETY SYMBOLS

The purpose of safety symbols is to attract your attention to possible dangers. The safety symbols and the explanations with them deserve your careful attention and understanding. The symbol warnings do not, by themselves, eliminate any danger. The instructions and warnings they give are no substitutes for proper accident prevention measures.

**⚠ WARNING:** Be sure to read and understand all safety instructions in this Operator's Manual, including all safety alert symbols such as "**DANGER**," "**WARNING**," and "**CAUTION**" before using this tool. Failure to follow all instructions listed below may result in electric shock, fire, and/or serious personal injury.

## SAFETY INSTRUCTIONS

This page depicts and describes safety symbols that may appear on this product. Read, understand, and follow all instructions on the machine before attempting to assemble and operate.

	Safety Alert	Precautions that involve your safety
	Read Operator's Manual	To reduce the risk of injury, user must read operator's manual.
	Indoor Use	Use this device indoors only
	Class II Construction	Double-insulated construction
	Fuse-links	Time-lag miniature fuse-link
V	Volt	Voltage
A	Amperes	Current
Hz	Hertz	Frequency (cycles per second)
W	Watt	Power
min	Minutes	Time
	Alternating Current	Type of current
	Direct Current	Type or a characteristic of current

**⚠ WARNING:** Read and understand all instructions. Failure to follow all instructions listed below may result in electric shock, fire and/or serious personal injury.

### WORK AREA SAFETY

- **Keep the work area clean and well lit.** Cluttered or dark areas invite accidents.
- **Do not operate the EGO charger in explosive environments, such as in the presence of flammable liquids, petrols, or dust.** A charger might create a spark, which may ignite the dust or fumes.

### ELECTRICAL SAFETY

- **Do not expose to the charger to rain or wet conditions.** Water entering the charger will increase the risk of electric shock.

- **Do not abuse the cord.** Never use the cord for carrying, pulling, or unplugging the charger. Keep the cord away from heat, oil, sharp edges, or moving parts. Damaged or entangled cords increase the risk of electric shock.
- The EGO charger can charge the EGO lithium-ion battery packs listed below:

CHARGER	BATTERY PACK
CHX5500E	BAX1500

## SERVICE

- **Have your charger serviced by a qualified repair person using only identical replacement parts.** This will ensure that the safety of the charger is maintained.
- **When servicing a charger, use only identical replacement parts. Follow instructions in the Maintenance section of this manual.** Use of unauthorized parts or failure to follow Maintenance instructions may create a risk of shock or injury.

## SAFETY RULES FOR CHARGER

**⚠ CAUTION:** This appliance is not intended for use by persons (including children) with reduced physical, sensory or mental capabilities, or lack of experience and knowledge, unless they have been given supervision or instruction concerning use of the appliance by a person responsible for their safety.

- **Before using the battery charger,** read all instructions and cautionary markings in this manual and on the battery charger, the battery and the product to prevent misuse of the products and possible injury or damage.
- **Do not handle charger, including the charger plug and charger terminals with wet hands.**
- **Make sure that the cord is located so that it will not be stepped on, tripped over, come in contact with sharp edges or moving parts, or otherwise be subjected to damage or stress.**  
This will reduce the risk of accidental falls, which could cause injury and damage to the cord, which could then result in electric shock.
- **Keep the cord and charger from heat to prevent damage to housing or internal parts.**
- **Do not allow petrol, oils, petroleum-based products, etc. to come in contact with plastic parts.** These materials contain chemicals that can damage, weaken, or destroy plastic.

- **Do not operate the charger with a damaged cord or plug, which could cause shorting and electric shock.** If damaged, have the charger repaired or replaced by an authorized service technician at an EGO Service Center.
- **Do not disassemble the charger.** Take it to an authorized service technician when service or repair is required. Incorrect reassembly may result in a risk of electric shock or fire.
- **Unplug the charger from the electrical outlet before attempting any maintenance or cleaning to reduce the risk of electric shock.**
- **Disconnect charger from the power supply when not in use.** This will reduce the risk of electric shock or damage to the charger if metal items should fall into the opening. It will also help prevent damage to the charger during a power surge.
- **Risk of electric shock.** Do not touch the uninsulated portion of output connector or uninsulated battery terminal.
- **Save these instructions.** Refer to them frequently and use them to instruct others who may use this tool. If you lend this tool to someone else, also lend these instructions to them to prevent misuse of the product and possible injury.

## IMPORTANT SAFETY INSTRUCTIONS

- **Save these instructions.** This manual contains important safety and operating instructions for EGO 56V Charger CHX5500E.
- **Before using the battery charger, read all instructions and cautionary markings on the battery charger, the battery and the product using the battery.**

## SPECIFICATIONS

Charger Input	220-240V~50Hz 550W
Charger Output	4/8A 56V
Charging Time	Charging BAX1500 (1568Wh) : 3.5 h (Rapid charge) 7 h (Normal charge)
Optimum Charging Temperature	5°C-40°C
Charger Weight	1.6 kg

## DESCRIPTION

### KNOW YOUR CHARGER (Fig. A)

1. Power Cord
2. Output Interface
3. Button
4. 1# LED (Green)
5. 2# LED (Green)
6. 3# LED (Red)
7. Input Interface
8. Wall Mounting Hole
9. Cooling Air Port

## OPERATION

### HOW TO CHARGE THE BATTERY PACK

**WARNING:** Do not use the charger outdoors or expose it to wet or damp conditions. Water entering the charger will increase the risk of electric shock.

**NOTICE:** Lithium-Ion battery packs are shipped partially charged. Before using it the first time, fully charge the battery pack.

1. Insert the separate power cord into the input interface (Fig. B).
2. Connect the charger to the power supply (220-240V/50Hz).
3. Insert the battery plug into the charger as Fig. C & D shown.
4. The charger will communicate with the battery pack to evaluate the condition of the battery pack.
5. When the battery pack is charging normally, the green 2# LED on the charger will flash. If keep the green button pressed for at least 1 second, the normal charging will transform to rapid charging and green 2# LED goes out with green 1# LED flashing.

The fan in the charger works continuously to cool the battery pack.

6. When the battery pack is fully charged, the charging indication LEDs stop blinking and will shine green continuously. Wait until the cooling fan stops, remove the battery pack from the charger and disconnect the charger from the power supply.
7. The battery pack will fully charge if left on the charger, but it will not overcharge.

### NOTICE:

- While the charger is connected to a power supply in step1, if the 3 LEDs still remain unlit, refer to the section on “**DEFECTIVE BATTERY PACK OR CHARGER**”.
- A significantly reduced running time after fully charging the battery pack indicates that the batteries are near the end of their usable life and must be replaced.
- The charger may warm during charging. This is part of the normal operation of the charger. Charge in a well-ventilated area.

## LED FUNCTIONS OF CHARGER

LED INDICATOR	BACKPACK BATTERY		LED ON THE CHARGER			ACTION
			1# LED (GREEN)	2# LED (GREEN)	3# LED (RED)	
	Defective		○	●		Battery pack or charger is defective
	Over temperature	Normal charging	○		●	Charging will begin when battery pack returns to normal temperature
		Rapid charging		○	●	Charging will begin when battery pack returns to normal temperature
	Normal charging		○		○	4A Charging
	Rapid charging			○	○	8A Charging
	Fully charged	Normal charging	○	●	○	Charging is completed
		Rapid charging	●	○	○	Charging is completed
—	Successful self-inspection		●	●	●	The charger could be used to charge the battery
●: On    ○: Off    : Flashing						

### CHARGING A HOT OR COLD BATTERY PACK

If the battery pack is out of the normal temperature range, 3# LED will shine red. When the battery pack cools down to approximately 57°C or warms to more than 3°C, the charger will automatically begin charging.

### DEFECTIVE BATTERY PACK OR CHARGER

Once the charger connects to a power supply, the charger will start self-inspection immediately.

1. If the self-inspection reaches a failure, all the LEDs will not blink or shine.

**Notice:** Try and reinsert the power cord into the charger and power supply in sequence. If the LEDs still read “failure” a second time, contact the EGO center to repair your charger.

2. If the charger passes the inspection, 3 LEDs will shine for 1s simultaneously, which means the charger can be used to charge the battery pack. While charging, if the charger defects a problem, 3# LED will begin flashing red or all the LEDs will turn off.

- If registering as defective, remove and reinsert the plug of battery pack into the charger. If the LEDs still read “defective” a second time, try charging a different battery pack.
- If a different battery pack charges normally, dispose of the defective battery pack (refer to the instructions in the battery pack manual).
- If a different battery pack also indicates “defective”, reconnect the charger to power supply again until the red 3# LED goes out. If all 3 LEDs still keep off or 3# LED flash red, the charger may be defective.

**⚠ WARNING:** It is not recommended to attempt charging while the charger confirmed as a defective one, it can cause electric shock or even serious injury.

### WALL-MOUNT HOLES

The charger has hanging holes for convenient storage. Install screws in the wall 76mm apart.

## MAINTENANCE

**⚠ WARNING:** To avoid serious personal injury, always disconnect the battery pack from the charger when cleaning or performing any maintenance.

**⚠ WARNING:** When servicing, use only identical EGO replacement parts. Use of any other parts may create a hazard or cause product damage.

**⚠ WARNING:** It is not recommended to use compressed dry air as a cleaning method of the charger. If cleaning with compressed air is the only method to apply, always wear safety goggles or safety glasses with side shields when cleaning the charger. If the operation is dusty, also wear a dust mask.

**⚠ WARNING:** If the power cord is damaged, use only identical power cord. Use of unauthorised power cord may create a risk of shock or injury.

### GENERAL MAINTENANCE

Avoid using solvents when cleaning plastic parts. Most plastics are susceptible to damage from various types of commercial solvents and may be damaged by their use. Use clean clothes to remove dirt, dust, oil, grease, etc.

**⚠ WARNING:** Do not at any time let brake fluids, petrol, petroleum-based products, penetrating oils, etc. to come in contact with plastic parts. Chemicals can damage, weaken or destroy plastic which may result in serious personal injury.

**⚠ WARNING:** When servicing, use only identical EGO replacement parts. Use of any other parts may create a hazard or cause product damage. To ensure safety and reliability, all repairs should be performed by a qualified service technician at an EGO Service Center.

### Protecting the environment



Do not dispose of electrical appliances as unsorted municipal waste, use separate collection facilities.

Contact your local government for information regarding the collection systems available.

If electrical appliances are disposed of in landfills or dumps, hazardous substances can leak into the groundwater and get into the food chain, damaging your health and well-being.

## TROUBLESHOOTING

PROBLEM	CAUSE	SOLUTION
Charger doesn't work. 3# LED flashes red or all the LEDs go out.	Battery pack or charger is defective or bad connection between the battery pack and charger.	<ul style="list-style-type: none"><li>■ Try to remove and reinsert the battery pack in the charger.</li><li>■ Try charging a different battery pack.</li><li>■ Unplug the charger and wait until the red LED goes out, then reconnect the plug to the power supply.</li></ul>
	Switch the charger too frequently	<ul style="list-style-type: none"><li>■ Connect the charger with the power supply after 30s since all the LEDs go out.</li></ul>
Charger doesn't work and 3# LED shines red.	Battery pack is too hot or too cold.	<ul style="list-style-type: none"><li>■ Allow the battery pack to reach normal temperature. Charging will begin when battery pack returns to normal temperature.</li></ul>



---

## WARRANTY

### EGO WARRANTY POLICY

2 year warranty on EGO Power+ System battery packs and chargers.

**Please contact EGO customer service on Australia 1300 000 EGO(1300 000 346),  
New Zealand 0508 000 EGO (0508 000 346)** any time you have questions or warranty claims.

### SERVICE WARRANTY

FOR TWO YEARS from the date of original retail purchase, the EGO Power+ System battery pack and charger are warranted against defects in material or workmanship. Defective product will receive free repair.

This warranty does not cover the blade, which is a part that can wear out from normal use within the warranty period.

- This warranty applies only to the original purchaser at retail and may not be transferred.
- Warranty for commercial use is 1 year on all product, battery and chargers. The Commercial Series Product Warranty for commercial users is 2 years for product, battery and charger.
- This warranty is void if the product has been used for rental purpose.
- This warranty does not cover the damage resulting from modification, alteration or unauthorised repair.
- This warranty only covers defects arising under normal usage and does not cover any malfunction, failure or defect resulting from misuse, abuse (including overloading of the product beyond capacity and exposure to water or rain), accidents, neglect or lack of proper installation, and improper maintenance or storage.
- This warranty does not cover normal deterioration of the exterior finish, including but not limited to scratches, dents, paint chips, or to any corrosion or discoloring by heat, abrasive and chemical cleaners.

## HOW TO OBTAIN SERVICE

For warranty service, please contact EGO customer service on Australia 1300 000 EGO(1300 000 346), New Zealand 0508 000 EGO (0508 000 346). When requesting warranty service, you must present the original dated sales receipt. An authorised service center will be selected to repair the product according to the stated warranty terms.

### ADDITIONAL LIMITATIONS

Chervon Australia Pty Ltd ABN 36 165 077 501 (“Chervon”) warrants to the original domestic purchaser that this product will be free from defects in materials and workmanship for 2 years from date of purchase, and any battery or charger will be free from defects in materials and workmanship for 2 years from date of purchase. To make a claim, return the faulty item together with proof of purchase directly to your closest service agent or to the place of purchase. Any handling and transportation costs (and other expenses incurred in claiming this warranty) are not covered by this warranty and will not be borne by Chervon. The replacement product or part or repaired product will be made available for your collection at an address nominated by Chervon. Where a valid warranty claim is made, Chervon will replace the defective product or repair the fault. Where the product is repaired, Chervon may use refurbished parts. This warranty does not cover normal wear and tear, misuse or abuse. This warranty may also be further limited or voided as specifically detailed in the product Manual. Chervon has no other liability under this warranty. The benefits to you given by this warranty are in addition to other rights and remedies imposed by State and Federal legislation that cannot be excluded. Our goods come with guarantees that cannot be excluded under the Australian Consumer Law. You are entitled to a replacement or refund for a major failure and compensation for any other reasonably foreseeable loss or damage. You are also entitled to have the goods repaired or replaced if the goods fail to be of acceptable quality and the failure does not amount to a major failure. Chervon Australia Pty Ltd, Unit Unit 14, 5 Kelleys Road, Rowville, VIC 3178.

Phone Number: Australia 1300 000 EGO(1300 000 346), New Zealand 0508 000 EGO (0508 000 346).

Email address: support@egopowerplus.com.au.

