

# EGO™

POWER<sup>+</sup> BACKPACK BATTERY

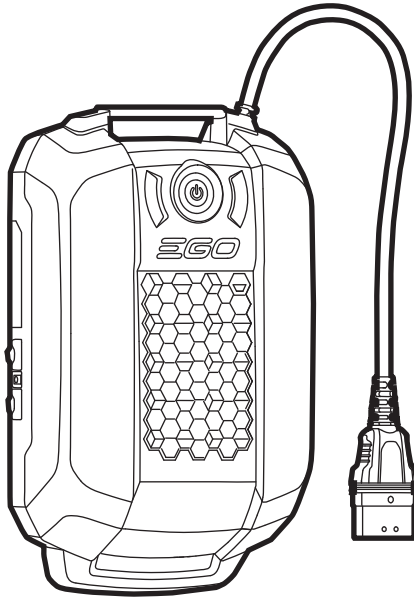

OPERATOR'S MANUAL

## 56 VOLT BACKPACK BATTERY

MODEL NUMBER BAX1500

**⚠ WARNING:** To reduce the risk of injury, the user must read and understand the Operator's Manual before using this product. Save these instructions for future reference.

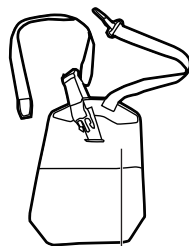
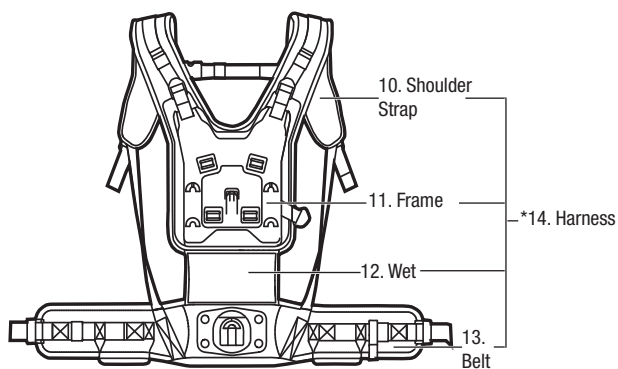
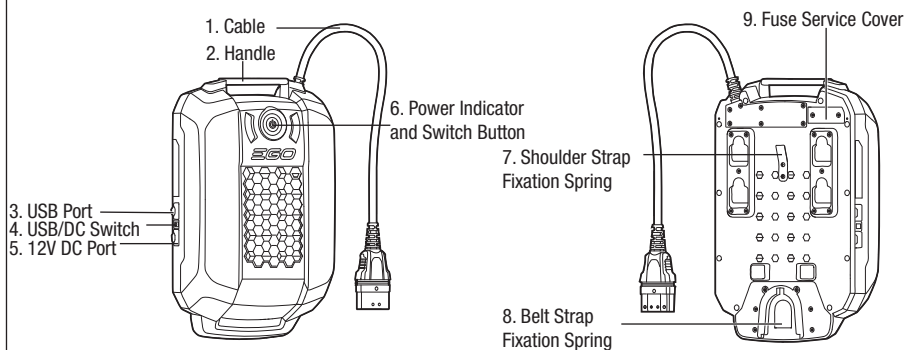
**A**

\*15. Hip-pad Accessory  
(Sold separately)

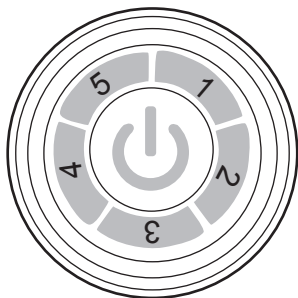
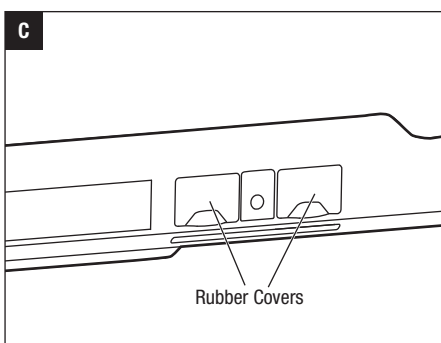
**B****C**

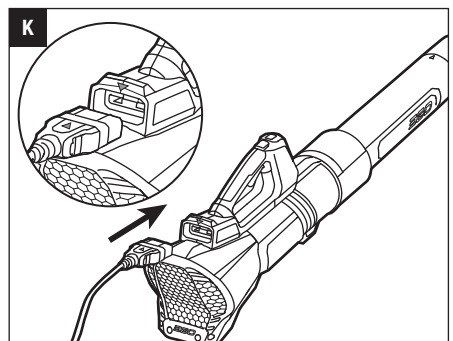
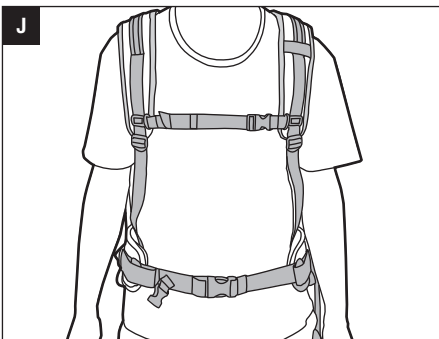
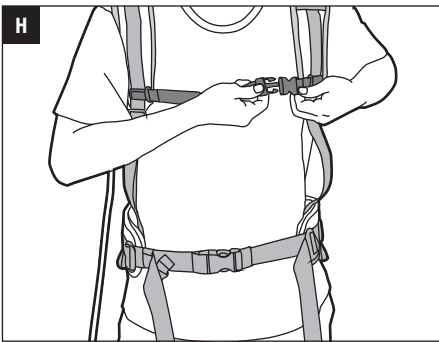
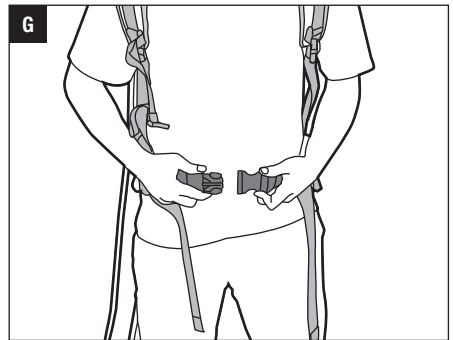
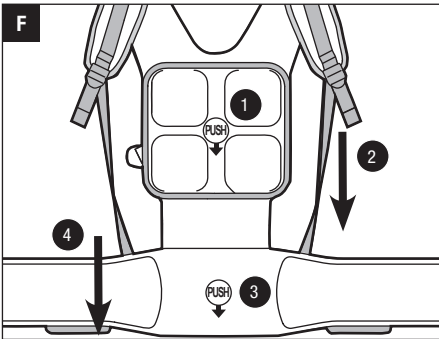
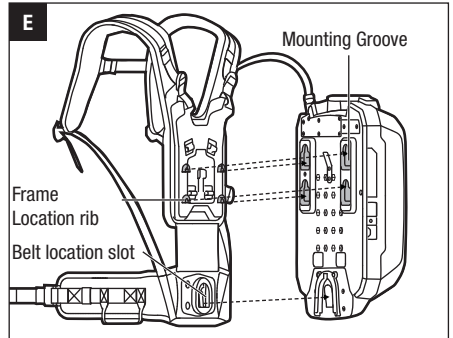
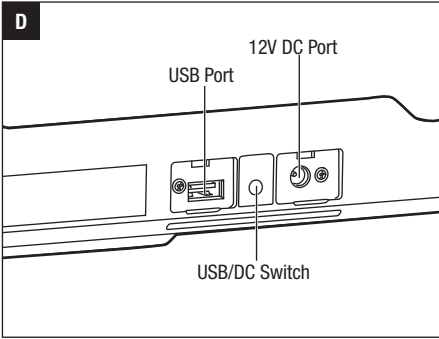

## READ ALL INSTRUCTIONS!



### READ OPERATOR'S MANUAL

**⚠ Residual risk!** People with electronic devices, such as pacemakers, should consult their physician(s) before using this product. Operation of electrical equipment in close proximity to a heart pacemaker could cause interference or failure of the pacemaker.

**⚠ WARNING:** To ensure safety and reliability, all repairs and replacements should be performed by a qualified service technician.

## SAFETY SYMBOLS

The purpose of safety symbols is to attract your attention to possible dangers. The safety symbols and the explanations with them deserve your careful attention and understanding. The symbol warnings do not, by themselves, eliminate any danger. The instructions and warnings they give are no substitutes for proper accident prevention measures.

**⚠ WARNING:** Be sure to read and understand all safety instructions in this Operator's Manual, including all safety alert symbols such as "**DANGER**," "**WARNING**," and "**CAUTION**" before using this tool. Failure to follow all instructions listed below may result in electric shock, fire, and/or serious personal injury.

**⚠ WARNING:** Risk of fire and burns. Do not disassemble, heat above 100 °C, or incinerate. Keep battery pack out of reach of children and in original package until ready to use. Dispose of used battery pack promptly according to local recycling or waste regulations.

## SAFETY INSTRUCTIONS

This page depicts and describes safety symbols that may appear on this product. Read, understand, and follow all instructions on the machine before attempting to assemble and operate it.

	Safety Alert	Indicates a potential personal injury hazard.
	Read operator's manual	To reduce the risk of injury, user must read and understand operator's manual before using this product.
	Recycle Symbols	Do not dispose of battery packs/batteries into household waste, fire or water. Battery packs/batteries should be collected, recycled or disposed of in an environmental friendly manner.
	WEEE	Waste electrical products should not be disposed of with household waste. Take to an authorized recycler.
IP56	IP Symbol	Protection against ingress of water degree 6 and dust degree 5
V	Volt	Voltage
A	Amperes	Current
W	Watt	Power
min	Minutes	Time
	Direct Current	Type or a characteristic of current

**⚠ WARNING:** Read and understand all instructions. Failure to follow all instructions may result in electric shock, fire and/or serious personal injury. The term "power tool" in most of warnings listed refers to EGO Power+ battery operated (cordless) Lawn & Garden machines.

### WORK AREA SAFETY

- **Keep the work area clean and well lit.** Cluttered or dark areas invite accidents.
- **Do not operate power tools in explosive environments, such as in the presence of flammable liquids, petrols, or dust. Power tools create sparks, which may ignite the dust or fumes.**

## ELECTRICAL SAFETY

- **Do not expose power tools to rain or wet conditions.**  
Water entering a power tool will increase the risk of electric shock.
- **Use only with chargers and power tools listed in “SPECIFICATIONS”.**

## BATTERY PACK USE AND CARE

- **When battery pack is not in use, keep it away from other metal objects like paper clips, coins, keys, nails screws or other small metal objects that can make a connection from one terminal to another.** Shorting the battery terminals together may cause burns or a fire.
- **Under abusive conditions, liquid may be ejected from the battery; avoid contact. If contact accidentally occurs, flush with water. If liquid contacts eyes, additionally seek medical help.** Liquid ejected from the battery may cause irritation or burns.
- **Do not dismantle, open or shred secondary battery.**
- **Do not expose the battery to heat or fire.** Avoid storage in direct sunlight.
- **Do not short-circuit a cell or a battery.** Do not store cells or batteries haphazardly in a box or drawer where they may short-circuit each other or be short-circuited by other metal objects.
- **Do not remove a battery from its original packaging until required for use.**
- **Do not subject cells or batteries to mechanical shock.**
- **Keep the battery out of the reach of children. Seek medical advice immediately if a battery has been swallowed.**
- **Keep the battery clean and dry.**
- **Wipe the battery terminals with a clean dry cloth if they become dirty.**
- **Secondary battery need to be charged before use.** Always use the correct charger and refer to the manufacturer's instructions or equipment manual for proper charging instructions.
- **Do not leave a battery on prolonged charge when not in use.**
- **After extended periods of storage, it may be necessary to charge and discharge the batteries several times to obtain maximum performance.**
- **Retain the original product literature for future reference.**
- **Use only the battery in the application for which it was intended.**

- **When possible, remove the battery from the equipment when not in use.**
- **Dispose of properly.**

## SERVICE

- **Follow instructions in the Maintenance section of this manual.** Use of unauthorised parts or failure to follow Maintenance instructions may create a risk of shock or injury.

## SPECIFIC SAFETY RULES

- **Know your power tool. Read the operator's manual carefully. Learn the applications and limitations, as well as the specific potential hazards related to the tool.** Following this rule will reduce the risk of electric shock, fire, or serious injury.
- **Battery tools do not have to be plugged into an electrical outlet; therefore, they are always in operating condition.** Be aware of possible hazards when not using your battery tool. Always remove the battery before changing accessories. Following this rule will reduce the risk of electric shock, fire or serious personal injury.
- **Do not crush, drop or damage the battery pack. Do not use a battery pack or charger that has been dropped or received a sharp blow.** A damaged battery is subject to explosion. Properly dispose of a dropped or damaged battery immediately.
- **Do not charge the battery in a damp or wet location.** Following this rule will reduce the risk of electric shock.
- **For best results, your battery should be charged in a location where the temperature is greater than 5°C and less than 40°C.** Do not store it outside or in vehicles.
- **Do not let petrol, oils, petroleum-based products, etc. come in contact with plastic parts.** These substances contain chemicals that can damage, weaken or destroy plastic.
- **Have your battery pack serviced by a qualified repairperson using only identical replacement parts.** This will ensure that the safety of the battery pack is maintained.
- **Save these instructions.** Refer to them frequently and use them to instruct others who may use this tool. If you lend someone this tool, lend them these instructions also to prevent misuse of the product and possible injury.

## SPECIFICATIONS

Rated Voltage	56V
Max Capacity	1568Wh
Matched Charger	CHX5500E
Charging Current	Rapid Charging: 8A Normal Charging: 4A
Charging Time	Rapid Charging: Approximately 3.5h Normal Charging: Approximately 7h
Weight	8.7kg
Specified ambient temperature range for discharging	-20 °C ~40 °C

## DESCRIPTION

### KNOW YOUR BATTERY PACK (Fig. A)

1. Cable
2. Handle
3. USB Port
4. USB/DC Switch
5. 12V DC Port
6. Power Indicator and Switch Button

7. Shoulder Strap Fixation Spring
8. Belt Strap Fixation Spring
9. Fuse Service Cover
10. Shoulder Strap
11. Frame
12. Wet
13. Belt
- \*14. Harness
- \*15. Hip-pad Accessory (Sold separately)

## OPERATION

### POWER INDICATOR ON BATTERY PACK (Fig. B)

This lithium-ion backpack battery is equipped with a power indicator, which indicates the charge capacity level and error of the battery pack. Press the power indicator to display the capacity level when the battery is not in charge. The LED indicator will shine for 10 seconds.

- In the case of charging, the LED indicator may display various interfaces listed below without pressing the switch button.

Battery Capacity / Error	CHARGING					Remarks
	LED's					
	1	2	3	4	5	
<20%	Flashing green	Off	Off	Off	Off	1 blinking
20% ≤ Capacity < 40%	On	Flashing green	Off	Off	Off	1 on, 1 blinking
40% ≤ Capacity < 60%	On	On	Flashing green	Off	Off	2 on, 1 blinking
60% ≤ Capacity < 80%	On	On	On	Flashing green	Off	3 on, 1 blinking
80% ≤ Capacity < 100%	On	On	On	On	Flashing green	4 on, 1 blinking
Capacity = 100% (fully charged)	On	On	On	On	On	5 on for several mins, then switch off
<b>Battery can't be charged</b>	Off	Off	Off	Off	Off	5 LED lights all will be switched off
<b>Over-temperature Battery</b>	Off	Off	Off	Off	Off	5 LED lights all will be switched off

If the backpack battery is discharging or remains unused, **PRESS THE SWITCH BUTTON**, the LED indicator will exhibit a different interface as shown below from the charging one.

DISCHARGING/UNUSED						
Battery Capacity / Error	LED's					Remarks
	1	2	3	4	5	
80% < Capacity ≤ 100%	On	On	On	On	On	5 LED lights on for 10 seconds after button-pressing
60% < Capacity ≤ 80%	On	On	On	On	Off	4 LED lights on for 10 seconds after button-pressing
40% < Capacity ≤ 60%	On	On	On	Off	Off	3 LED lights on for 10 seconds after button-pressing
20% < Capacity ≤ 40%	On	On	Off	Off	Off	2 LED lights on for 10 seconds after button-pressing
10% < Capacity ≤ 20%	On	Off	Off	Off	Off	1 LED light on for 10 seconds after button-pressing
≤10%	Flashing green	Off	Off	Off	Off	1 LED light blinks for 10 seconds after button-pressing
<b>Under voltage (&lt;2.7V)</b>	Flashing red	Flashing red	Flashing red	Flashing red	Flashing red	5 red light blinks for 10 seconds after button-pressing
<b>Over-temperature Battery</b>	Shining red	Shining red	Shining red	Shining red	Shining red	5 red light on for 10 seconds after button-pressing

## BATTERY PROTECTION

The battery circuitry protects the battery pack from extreme temperature, over-discharge and over-charge. To protect the battery from damage and prolong its life, the battery pack circuitry will turn off the battery pack if it becomes overloaded or if the temperature becomes too high or too low during use. This may happen in extremely high torque, binding, and stalling situations.

- In the case of charging, the battery pack will shut down with all 5 LEDs being switched off when its temperature exceeds 60°C or below 0°C. Once the temperature returns back to normal in 90 minutes, the battery will return to work automatically. Otherwise, the battery will shut down, reinsert the plug into the charger again, can reactivate charging.
- The battery pack will also shut down with all 5 LEDs being switched off when the voltage of a battery cell exceeds its protective voltage. It is recommended to discharge the battery pack immediately. If this tip is repeated many times, please contact with EGO service centers.

- In the case of discharging, when the temperature of battery pack exceeds 70°C or below -20°C, the battery pack will shut down with the 5 LED shining red for 10s after button-pressing. The battery pack will return to work in both conditions when normal temperature resumes and will allow the power tool to restart.
- When the voltage of a battery cell is less than 2.7V, the battery pack will shut down with the 5 LED blinking red for 10s after button-pressing. It is recommended to stop work and charge your battery pack immediately. If this tip is repeated many times, contact your service technician for assistant.

**⚠ WARNING:** You should never heat the battery pack under any circumstances.

## CHARGE THE BATTERY PACK

The battery pack is shipped partially charged. Before using it for the first time the battery should be charged.

**⚠ WARNING:** Do not charge the battery pack outdoors or expose it to wet or damp conditions. Water entering the charger or battery pack will increase the risk of electric shock. For any additional details, please refer to the Operator's Manual for the EGO CHX5500E Charger.

1. Connect the charger to the power supply (220-240V~50Hz).
2. Insert the battery plug into the charger.
3. If the battery pack is in the normal charging, the green LED1 on the charger will flash. After green button-pressing for at least 1s, the normal charging (charging current 4A) will transform to rapid charging (charging current 8A) and green LED2 on the charger will flash with LED1 off.
4. 5 LEDs of battery pack shining green continuously means the battery pack is fully charged. Wait until the cooling fan of the charger stops, remove the battery pack from the charger and disconnect the charger from power supply.

#### NOTICE:

- The battery pack will fully charge if left on the charger, but it will not overcharge.
- Following the instructions in the Operator's Manual for the EGO CHX5500E charger for more details.
- A significantly reduced running after fully charging the battery pack indicates that the batteries are near the end of their usable life and must be replaced.
- If you have not inserted the plug into its place completely, LED of charger light would flash continually.
- The charger may warm during charging. This is part of the normal operation of the charger. Charge in a well-ventilated area.

#### USB/12V DC

Uncover the rubber covers and insert the USB/DC plugs into USB/DC ports (Fig. C & D). Then press the USB/DC switch button, the battery pack will connect the devices via USB or DC ports.

#### NOTICE:

- The functions of USB and 12V DC power can work with 56V power source simultaneously. After using of USB/12V DC, pull out the USB/DC plugs and put the rubber covers into its place.
- Should not use the USB/12V DC while the battery pack is charging.

#### CONNECT AND DISCONNECT HARNESS TO/FROM BATTERY PACK

##### To Connect

Align the four location ribs on the frame with the mounting grooves and connect the location slot on the belt with the belt fixation spring. Then slide the harness up until a click happening. (fig.E).

##### To Disconnect

Press the two release buttons on harness behind the frame and slide the harness out (Fig. F).

#### PUT ON THE BATTERY PACK

In normal operation, the battery pack with the harness is worn on the back. To prevent fatigue and work comfortably, the harness is equipped with a belt joint and shoulder strap joints, which guarantees freedom of movement.

The belt length of the lap belt and shoulder straps can be adjusted freely. The back cushion should fit firmly and securely on your back.

- Adjust the belt and shoulder strap length to make yourself comfortable before normal work, the length should fit your body size through the lap belt and shoulder strap joint.
- Insert the two parts of the belt buckle and chest buckle into each other until a click occurs (Fig. G & H).
- Adjust the height of the chest buckle to make yourself comfortable (Fig. I).
- Readjust the length of the belt strap and chest strap.
- Insert any extra length of belt around the waist and chest strap into the elastic (Fig. J).

#### TO ATTACH AND DETACH THE BATTERY PACK

##### Charge before first use

Guide the battery pack cable around the side of the body, and connect the power tools to the 1.5m connection cable. Follow the instructions in the power tools' manual for the further details.

##### To Install (Fig. K)

With aligned ▲ logo respectively on the plug and the power tools, insert the plug into the power tools until the green seal completely disappearing into the socket.

##### To Remove

Pull the plug out of the power tools.



**⚠ WARNING:** When emergency occurs, take off the battery pack from your shoulder immediately. Releasing the belt and chest buckle, then taking off the shoulder harness at each side is a quick release method.

**⚠ WARNING:** Do not over tighten the shoulder straps as it may make it difficult to remove the battery pack.

**⚠ WARNING:** Only certain EGO products can match the battery pack, which is listed in "SPECIFICATION". We recommend you should not use the battery pack on other power tools.

## MAINTENANCE

**⚠ WARNING:** The battery pack must be repaired or replaced in EGO qualified service centre and technicians.

**⚠ WARNING:** To avoid serious personal injury, always remove the battery pack from the tool when changing accessories, cleaning or performing any maintenance.

**⚠ WARNING:** When servicing, use only identical EGO replacement parts. Use of any other parts may create a hazard or cause product damage.

**⚠ WARNING:** If cleaning with compressed air is the only method to apply, always wear safety goggles or safety glasses with side shields. If the operation is dusty, also wear a dust mask.

## GENERAL MAINTENANCE

Avoid using solvents when cleaning plastic parts. Most plastics are susceptible to damage from various types of commercial solvents and may be damaged by their use. Use clean clothes to remove dirt, dust, oil, grease, etc.

**⚠ WARNING:** Do not let brake fluids, petrol, petroleum-based products, penetrating oils, etc. come in contact with plastic parts at any time. Chemicals can damage, weaken or destroy plastic which may result in serious personal injury.

## BATTERIES

Do not disassemble the battery pack or attempt to replace the cells. Handling of the batteries, especially when wearing rings and jewelry could result in serious burns. To obtain the longest possible battery life, read and understand the operator's manual.

**⚠ WARNING:** It is good practice to unplug the charger and remove the battery pack when not in use.

## BATTERY PACK REMOVAL AND PREPARATION FOR RECYCLING



Do not dispose of battery charger and batteries/rechargeable batteries into household waste!

Electrical and electronic equipment that is no longer usable, defective or used battery packs/batteries, must be collected separately and disposed of in an environmentally correct manner.

### Li-ion

Consult your local waste authority for information regarding available recycling and/or disposal options.

**⚠ WARNING:** Upon removal of the battery pack for disposal or recycling, cover the battery pack's terminals with EN heavy-duty adhesive tape. Do not attempt to destroy or disassemble the battery pack or remove any of its components. Lithium-Ion batteries must be recycled or disposed of properly. Also, never touch the terminals with metal objects and/or body parts as a short circuit may result. Keep away from children. Failure to comply with these warnings could result in fire and/or serious injury.

## TROUBLESHOOTING

PROBLEM	CAUSE	SOLUTION
The power tools doesn't work	<ul style="list-style-type: none"><li>■ No electrical contact between the power tool and battery.</li><li>■ The battery pack is depleted.</li><li>■ The battery pack or power tool is too hot.</li><li>■ The cable or plug is out of work.</li><li>■ The voltage of a battery cell is below 2.7V.</li></ul>	<ul style="list-style-type: none"><li>■ Attached the battery pack to the power tool.</li><li>■ Charge the battery pack.</li><li>■ Cool the battery pack or power tool until the temperature drops to normal values.</li><li>■ Contact with EGO service centers.</li><li>■ Charge the battery pack immediately.</li></ul>
The battery pack can't be Charged	<ul style="list-style-type: none"><li>■ The battery temperature exceeds or reduces below the specified value.</li><li>■ No electrical contact between battery and charger.</li><li>■ The connection between the charger and power source goes wrong.</li></ul>	<ul style="list-style-type: none"><li>■ Stop charging or discharging until the temperature becomes normal.</li><li>■ Reinsert the battery pack into the charger.</li><li>■ Reinsert the charger plug into the power source.</li></ul>

---

## WARRANTY

### EGO WARRANTY POLICY

1 year warranty on EGO Power+ System battery packs and chargers.

**Please contact EGO customer service on Australia 1300 000 EGO(1300 000 346), New Zealand 0508 000 EGO (0508 000 346)** any time you have questions or warranty claims.

### SERVICE WARRANTY

FOR ONE YEAR from the date of original retail purchase, the EGO Power+ System Battery Pack and Charger are warranted against defects in material or workmanship. Defective product will receive free repair.

- This warranty applies only to the original purchaser at retail and may not be transferred.
- The warranty period for any EGO product or part used for industrial, professional or commercial purpose is one year.
- This warranty is void if the product has been used for rental purpose.
- This warranty does not cover the damage resulting from modification, unauthorised or unauthorized repair.
- This warranty only covers defects arising under normal usage and does not cover any malfunction, failure or defect resulting from misuse, abuse (including overloading of the product beyond capacity and exposure to water or rain), accidents, neglect or lack of proper installation, and improper maintenance or storage.
- This warranty does not cover normal deterioration of the exterior finish, including but not limited to scratches, dents, paint chips, or to any corrosion or discoloring by heat, abrasive and chemical cleaners.

## HOW TO OBTAIN SERVICE

For warranty service, please contact EGO customer service on Australia 1300 000 EGO(1300 000 346), New Zealand 0508 000 EGO (0508 000 346). When requesting warranty service, you must present the original dated sales receipt. An authorised service center will be selected to repair the product according to the stated warranty terms.

### ADDITIONAL LIMITATIONS

Chervon Australia Pty Ltd ABN 36 165 077 501 (“Chervon”) warrants to the original domestic purchaser that this product will be free from defects in materials and workmanship for 1 year from date of purchase, and any battery or charger will be free from defects in materials and workmanship for 1 year from date of purchase. To make a claim, return the faulty item together with proof of purchase directly to your closest service agent or to the place of purchase. Any handling and transportation costs (and other expenses incurred in claiming this warranty) are not covered by this warranty and will not be borne by Chervon. The replacement product or part or repaired product will be made available for your collection at an address nominated by Chervon. Where a valid warranty claim is made, Chervon will replace the defective product or repair the fault. Where the product is repaired, Chervon may use refurbished parts. This warranty does not cover normal wear and tear, misuse or abuse. This warranty may also be further limited or voided as specifically detailed in the product Manual. Chervon has no other liability under this warranty. The benefits to you given by this warranty are in addition to other rights and remedies imposed by State and Federal legislation that cannot be excluded. Our goods come with guarantees that cannot be excluded under the Australian Consumer Law. You are entitled to a replacement or refund for a major failure and compensation for any other reasonably foreseeable loss or damage. You are also entitled to have the goods repaired or replaced if the goods fail to be of acceptable quality and the failure does not amount to a major failure. Chervon Australia Pty Ltd, Unit 14, 5 Kelletts Road, Rowville, VIC 3178.  
Phone Number: Australia 1300 000 EGO(1300 000 346), New Zealand 0508 000 EGO (0508 000 346).  
Email address: support@egopowerplus.com.au.

