

EGO™

POWER⁺ CHARGER

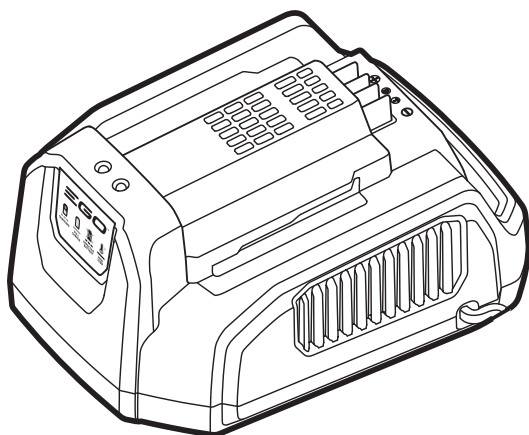

OPERATOR'S MANUAL
56-VOLT CHARGER
MODEL NUMBER CH2100E

⚠ WARNING: To reduce the risk of injury, the user must read and understand the Operator's Manual before using this product. Save these instructions for future reference.

A

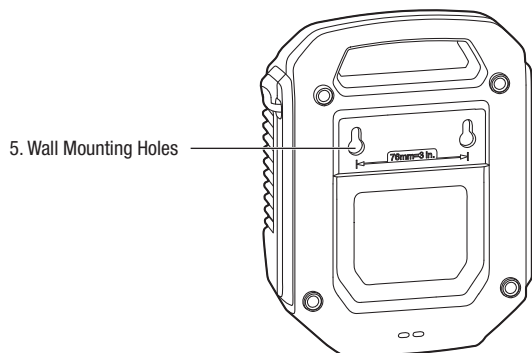
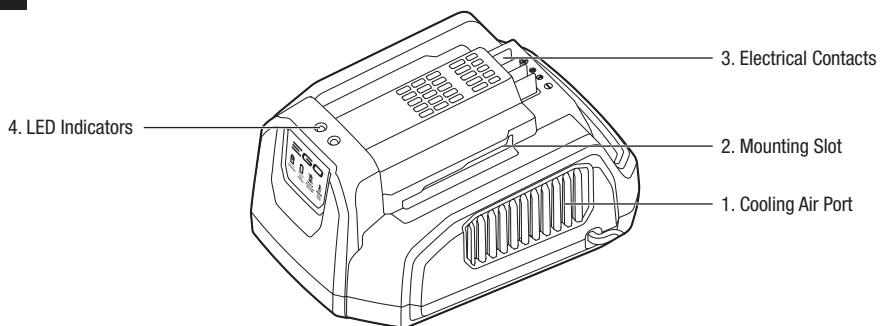

B

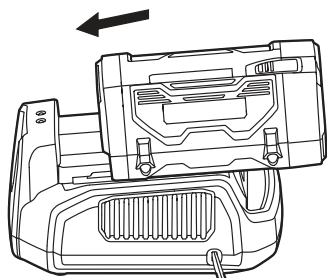

READ ALL INSTRUCTIONS!



READ OPERATOR'S MANUAL

⚠ Residual risk! People with electronic devices, such as pacemakers, should consult their physician(s) before using this product. Operation of electrical equipment in close proximity to a heart pacemaker could cause interference or failure of the pacemaker.

⚠ WARNING: To ensure safety and reliability, all repairs should be performed by a qualified service technician.

⚠ WARNING: This appliance is not intended for use by persons (including children) with reduced physical, sensory or mental capabilities, or lack of experience and knowledge, unless they have been given supervision or instruction concerning use of the appliance by a person responsible for their safety. Children should be supervised to ensure that they do not play with the appliance.

SAFETY SYMBOLS

The purpose of safety symbols is to attract your attention to possible dangers. The safety symbols and the explanations with them deserve your careful attention and understanding. The symbol warnings do not, by themselves, eliminate any danger. The instructions and warnings they give are no substitutes for proper accident prevention measures.

⚠ WARNING: Be sure to read and understand all safety instructions in this Operator's Manual, including all safety alert symbols such as "**DANGER**," "**WARNING**," and "**CAUTION**" before using this tool. Failure to follow all instructions listed below may result in electric shock, fire, and/or serious personal injury.

SAFETY INSTRUCTIONS

This page depicts and describes safety symbols that may appear on this product. Read, understand, and follow all instructions on the machine before attempting to assemble and operate.

| | | |
|-------------|------------------------|--|
| | Safety Alert | Precautions that involve your safety. |
| | Read Operator's Manual | To reduce the risk of injury, user must read operator's manual |
| | Indoor Use | Use this device indoors only |
| | Class II Construction | Double-insulated construction |
| T3, 15A | Fuse-links | Time-lag miniature fuse-link |
| V | Volt | Voltage |
| A | Amperes | Current |
| Hz | Hertz | Frequency (cycles per second) |
| W | Watt | Power |
| min | Minutes | Time |
| | Alternating Current | Type of current |
| | Direct Current | Type or a characteristic of current |

⚠ WARNING: Read and understand all instructions. Failure to follow all instructions listed below may result in electric shock, fire and/or serious personal injury.

WORK AREA SAFETY

- **Keep the work area clean and well lit.** Cluttered or dark areas invite accidents.
- **Do not operate the EGO charger in explosive environments, such as in the presence of flammable liquids, gases, or dust.** A charger might create a spark, which may ignite the dust or fumes.

ELECTRICAL SAFETY

- **Power tool plugs must match the outlet.** Never modify the plug in any way. Do not use any adapter plugs with grounded power tools. Unmodified plugs and matching outlets will reduce the risk of electric shock.
- **Do not expose to the charger to rain or wet conditions.** Water entering the charger will increase the risk of electric shock.

- **Do not abuse the cord.** Never use the cord for carrying, pulling, or unplugging the charger. Keep the cord away from heat, oil, sharp edges, or moving parts. Damaged or entangled cords increase the risk of electric shock.
- **Avoid body contact with grounded surfaces, such as pipes, radiators, ranges, and refrigerators.** There is an increased risk of electric shock if your body is grounded.
- **When operating a power tool outdoors, use an extension cord suitable for outdoor use.** Use of a cord suitable for outdoor use reduces the risk of electric shock.
- The EGO charger can charge the EGO lithium-ion battery packs listed below:

| CHARGER | BATTERY PACKS |
|---------|--|
| CH2100E | BA1120E, BA1400, BA2240E, BA2800, BA3360, BA4200 |

SERVICE

- **Have your charger serviced by a qualified repair person using only identical replacement parts.** This will ensure that the safety of the charger is maintained.
- **When servicing a charger, use only identical replacement parts. Follow instructions in the Maintenance section of this manual.** Use of unauthorized parts or failure to follow Maintenance instructions may create a risk of shock or injury.

SAFETY RULES FOR CHARGER

⚠ CAUTION: To reduce the risk of electric shock or damage to the charger and battery, charge only those lithium-ion rechargeable batteries specifically designated on your charger's label. Other types of batteries may burst, causing personal injury or damage.

- This appliance is not intended for use by persons (including children) with reduced physical, sensory or mental capabilities, or lack of experience and knowledge, unless they have been given supervision or instruction concerning use of the appliance by a person responsible for their safety.
- **Before using the battery charger,** read all instructions and cautionary markings in this manual and on the battery charger, the battery and the product using the battery to prevent misuse of the products and possible injury or damage.
- **Do not use the charger outdoors or expose it to wet or damp conditions.** Water entering the charger will increase the risk of electric shock.

- **Do not handle charger, including the charger plug and charger terminals with wet hands.**
- **Use of an attachment not recommended or sold by the battery-charger manufacturer may result in a risk of fire, electric shock, or injury to persons.**
- **Recharge only with the charger specified by the manufacturer.** A charger that is suitable for one type of battery pack may create a risk of fire when used with another battery pack.
- **Do not abuse the cord or charger.** Never use the cord to carry the charger. Do not pull the charger cord to disconnect the plug from a receptacle. Damage to the cord or charger could occur and create an electric shock hazard. Replace damaged cords immediately.
- **Make sure that the cord is located so that it will not be stepped on, tripped over, come in contact with sharp edges or moving parts, or otherwise be subjected to damage or stress.** This will reduce the risk of accidental falls, which could cause injury and damage to the cord, which could then result in electric shock.
- **Keep the cord and charger away from heat to prevent damage to housing or internal parts.**
- **Do not allow gasoline, oils, petroleum-based products, etc. to come in contact with plastic parts.** These materials contain chemicals that can damage, weaken, or destroy plastic.
- **Do not operate the charger with a damaged cord or plug, which could cause shorting and electric shock.** If damaged, have the charger repaired or replaced by an authorized service technician at an EGO Service Center.
- **Do not operate the charger if it has received a sharp blow, been dropped, or has otherwise been damaged in any way.** Take it to an authorized service technician for an electrical check to determine if the charger is in good working order.
- **Do not disassemble the charger.** Take it to an authorized service technician when service or repair is required. Incorrect reassembly may result in a risk of electric shock or fire.
- **Unplug the charger from the electrical outlet before attempting any maintenance or cleaning to reduce the risk of electric shock.**
- **Disconnect charger from the power supply when not in use.** This will reduce the risk of electric shock or damage to the charger if metal items should fall into the opening. It will also help prevent damage to the charger during a power surge.
- **Risk of electric shock.** Do not touch the uninsulated portion of output connector or uninsulated battery terminal.

- **Save these instructions.** Refer to them frequently and use them to instruct others who may use this tool. If you lend this tool to someone else, also lend these instructions to them to prevent misuse of the product and possible injury.

IMPORTANT SAFETY INSTRUCTIONS

- **Save these instructions.** This manual contains important safety and operating instructions for EGO 56V Charger CH2100E.
- **Before using the battery charger, read all instructions and cautionary markings on the battery charger, the battery and the product using the battery.**

⚠ WARNING: When using electric appliances, basic precautions should always be followed, including the following.

- To reduce the risk of injury, close supervision is necessary when an appliance is used near children.
- Only use attachments recommended or sold by manufacturer.
- Do not use outdoors.
- For a portable appliance – To reduce the risk of electrical shock, do not put charger in water or other liquid. Do not place or store appliance where it can fall or be pulled into a tub or sink.

⚠ CAUTION: To reduce the risk of injury, charge only lithium-ion rechargeable batteries. Other types of batteries may burst, causing personal injury or damage.

SPECIFICATIONS

| | |
|------------------------------|--|
| Charger Input | 220-240V~ 50Hz 210W |
| Charger Output | 3A 56V |
| Charging Time | Approximately 40 minutes for BA1120E battery pack. |
| | Approximately 50 minutes for BA1400 battery pack. |
| | Approximately 80 minutes for BA2240E battery pack. |
| | Approximately 100 minutes for BA2800 battery pack. |
| | Approximately 115 minutes for BA3360 battery pack. |
| | Approximately 145 minutes for BA4200 battery pack. |
| Optimum Charging Temperature | 0°C-40°C |
| Charger Weight | 1.2 kg |

DESCRIPTION

KNOW YOUR CHARGER (Fig. A)

1. Cooling Air Port
2. Mounting Slot
3. Electrical Contacts
4. LED Indicators
5. Wall Mounting Holes

OPERATION

HOW TO CHARGE THE BATTERY PACK

⚠ WARNING: Do not use the charger outdoors or expose it to wet or damp conditions. Water entering the charger will increase the risk of electric shock.





NOTICE: Lithium-Ion battery packs are shipped partially charged. Before using it the first time, fully charge the battery pack.

1. Connect the charger to the power supply (220-240V~ 50Hz).
2. Align the raised ribs of the battery pack with the mounting slots in the charger; slide the battery pack down onto the charger as Fig. B shown.
3. The charger will communicate with the battery pack to evaluate the condition of the battery pack.
4. When the battery pack is charging, the green LED on the charger will flash. The power indicator on the battery pack will flash in sequence: red, orange and green. The fan in the charger continuously works to cool the battery pack.
5. When the battery pack is fully charged, the green LED will stop flashing and will shine green continuously. The power indicator on the battery pack will go out. Wait until the cooling fan stops, remove the battery pack from the charger and disconnect the charger from the power supply.
6. The battery pack will fully charge if left on the charger, but it will not overcharge. If the battery pack remains on the charger for one month or more, it will perform self-maintenance and drop to 30% charge capacity. If this occurs, reinstall the battery pack on the charger to recharge it fully.

NOTICE:

- A significantly reduced run time after fully charging the battery pack indicates that the batteries are near the end of their usable life and must be replaced.
- The charger may warm during charging. This is part of the normal operation of the charger. Charge in a well-ventilated area.

LED FUNCTIONS OF CHARGER

| LED Indicator | Battery Pack | Red LED on the Charger | Green LED on the Charger | Power Indicator on the Battery Pack | ACTION |
|--|------------------|------------------------|-------------------------------|--|---|
|  CHARGING | Charging | Off | Flashing | Flashing red, orange and green alternatively | Charging |
|  DEFECTIVE BATTERY | Defective | Flashing | Off | Off | Battery pack or charger is defective. |
|  HIGH TEMP | Cold/Hot Battery | On | Off | Off | Charging will begin when battery pack returns to 3°C-57°C. |
|  FULL CHARGE | Fully charged | Off | On | Off | Charging is complete. Maintenance charging. |
| ... | Self-maintenance | Off | Intermittently quick flashing | Off | Battery pack is performing self-maintenance or in sleep mode. Reinstall the battery pack on the charger to recharge it fully. |

CHARGING A HOT OR COLD BATTERY PACK

If the battery pack is out of the normal temperature range, the red LED will shine and the green LED will go off. When the battery pack cools down to approximately 57°C or warms to more than 3°C, the charger will automatically begin charging.

DEFECTIVE BATTERY PACK OR CHARGER

If the charger detects a problem, the red LED will begin flashing and the green LED will go off.

1. If registering as defective, remove and reinsert the battery pack in the charger. If the LEDs still read “defective” a second time, try charging a different battery pack.
2. If a different battery pack charges normally, dispose of the defective battery pack (refer to the instructions in the battery pack manual).
3. If a different battery pack also indicates “defective”, unplug the charger and wait until the red LED goes out, then reconnect the plug to the power supply. If the red LED on charger still display defective, the charge may be defective.

WALL-MOUNT HOLES

The charger has hanging holes for convenient storage. Install screws in the wall 76mm apart. Use screws sufficiently strong to hold the combined weight of the charger and battery pack (approximately maximum 3.3kg).

MAINTENANCE

⚠ WARNING: To avoid serious personal injury, always remove the battery pack from the tool when cleaning or performing any maintenance.

⚠ WARNING: When servicing, use only identical EGO replacement parts. Use of any other parts may create a hazard or cause product damage.

⚠ WARNING: It is not recommended to use compressed dry air as a cleaning method of the charger. If cleaning with compressed air is the only method to apply, always wear safety goggles or safety glasses with side shields when cleaning the tool. If the operation is dusty, also wear a dust mask.

⚠ WARNING: If the supply cord is damaged, it must be replaced by the manufacturer, its service agent or similarly qualified persons in order to avoid a hazard.

GENERAL MAINTENANCE

Avoid using solvents when cleaning plastic parts. Most plastics are susceptible to damage from various types of commercial solvents and may be damaged by their use.

Use clean cloths to remove dirt, dust, oil, grease, etc.

⚠ WARNING: Do not at any time let brake fluids, gasoline, petroleum-based products, penetrating oils, etc. come in contact with plastic parts. Chemicals can damage, weaken or destroy plastic which may result in serious personal injury.

⚠ WARNING: When servicing, use only identical EGO replacement parts. Use of any other parts may create a hazard or cause product damage. To ensure safety and reliability, all repairs should be performed by a qualified service technician at an EGO Service Center.

Protecting the environment



Do not dispose of electrical appliances as unsorted municipal waste, use separate collection facilities.

Contact your local government for information regarding the collection systems available.

If electrical appliances are disposed of in landfills or dumps, hazardous substances can leak into the groundwater and get into the food chain, damaging your health and well-being.

TROUBLESHOOTING

| PROBLEM | CAUSE | SOLUTION |
|---|--|---|
| Charger doesn't work. The red LED flashes red or all the LEDs go out. | Battery pack or charger is defective or bad connection between the battery pack and charger. | <ul style="list-style-type: none"> ■ Try to remove and reinsert the battery pack in the charger. ■ Try charging a different battery pack. ■ Unplug the charger and wait until the red LED goes out, then reconnect the plug to the power supply. |
| Charger doesn't work and red LED shines red. | Battery pack is too hot or too cold. | Allow the battery pack to reach normal temperature. Charging will begin when battery pack returns to 3°C-57°C. |
| The charger produces a rhythmic sound and the power indicator on the battery pack is OFF. | The battery pack is over-discharged. | Leave the battery on the charger and check in 30 minutes to see if the power indicator on the battery pack turns on. If yes, the battery pack is activated successfully. If no, the battery pack may be damaged. |



WARRANTY

EGO WARRANTY POLICY

3 year warranty on EGO Power+ System battery packs and chargers.

Please contact EGO customer service on Australia 1300 000 EGO(1300 000 346), New Zealand 0508 000 EGO (0508 000 346) any time you have questions or warranty claims.

SERVICE WARRANTY

FOR THREE YEARS from the date of original retail purchase, the EGO Power+ System Battery Pack and Charger are warranted against defects in material or workmanship. Defective product will receive free repair.

- This warranty applies only to the original purchaser at retail and may not be transferred.
- The warranty period for any EGO product or part used for industrial, professional or commercial purpose is one year.
- This warranty is void if the product has been used for rental purpose.
- This warranty does not cover the damage resulting from modification, alteration or unauthorized repair.
- This warranty only covers defects arising under normal usage and does not cover any malfunction, failure or defect resulting from misuse, abuse (including overloading of the product beyond capacity and exposure to water or rain), accidents, neglect or lack of proper installation, and improper maintenance or storage.
- This warranty does not cover normal deterioration of the exterior finish, including but not limited to scratches, dents, paint chips, or to any corrosion or discoloring by heat, abrasive and chemical cleaners.

HOW TO OBTAIN SERVICE

For warranty service, please contact EGO customer service on Australia 1300 000 EGO(1300 000 346), New Zealand 0508 000 EGO (0508 000 346). When requesting warranty service, you must present the original dated sales receipt. An authorized service center will be selected to repair the product according to the stated warranty terms.

ADDITIONAL LIMITATIONS

Chervon Australia Pty Ltd ABN 36 165 077 501 ("Chervon") warrants to the original domestic purchaser that this product will be free from defects in materials and workmanship for 5 years from date of purchase, and any battery or charger will be free from defects in materials and workmanship for 3 years from date of purchase. To make a claim, return the faulty item together with proof of purchase directly to your closest service agent or to the place of purchase. Any handling and transportation costs (and other expenses incurred in claiming this warranty) are not covered by this warranty and will not be borne by Chervon. The replacement product or part or repaired product will be made available for your collection at an address nominated by Chervon. Where a valid warranty claim is made, Chervon will replace the defective product or repair the fault. Where the product is repaired, Chervon may use refurbished parts. This warranty does not cover normal wear and tear, misuse or abuse. This warranty may also be further limited or voided as specifically detailed in the product Manual. Chervon has no other liability under this warranty. The benefits to you given by this warranty are in addition to other rights and remedies imposed by State and Federal legislation that cannot be excluded. Our goods come with guarantees that cannot be excluded under the Australian Consumer Law. You are entitled to a replacement or refund for a major failure and compensation for any other reasonably foreseeable loss or damage. You are also entitled to have the goods repaired or replaced if the goods fail to be of acceptable quality and the failure does not amount to a major failure. Chervon Australia Pty Ltd, Unit 13, 1488 Ferntree Gully Rd, Knoxfield, VIC. 3180. Phone Number: Australia 1300 000 EGO(1300 000 346), New Zealand 0508 000 EGO (0508 000 346). Email address: support@egopowerplus.com.au.

